



ABOUT US

堂瑩發展歷程及經營理念 | DEVELOPMENT AND MANAGEMENT CONCEPT

堂瑩是臺灣最早接觸機械、工業用離合器、制動器的公司之一，歷經三十餘年發展與經驗的積累，已成為臺灣專業化生產工業精品的廠家。三十餘年來堂瑩秉持一貫的品質經營理念，致力於STEKI品牌的推廣，務求帶給用戶最完善的服務。

我們提供完整、高品質的產品組合：空壓離合器、空壓制動器（氣動離合器、氣動制動器）、空油壓碟式制動器、電磁離合器、電磁制動器、磁粉離合器、磁粉制動器、磁滯離合器、磁滯制動器、張力控制系統、鏈條式氣脹軸、板條式氣脹軸、通條式氣脹軸、超耐用安全夾頭。產品廣泛應用於：印刷機械、包裝機械、瓦楞機械、纜纜設備、紡織機械、橡膠機械、輪胎機械、電工機械、制紙機械、建設機械、食品機械、合板機械、風力發電設備、新能源設備.....

對創新無限熱愛

技術是堂瑩的核心，因為我們持續不斷的投入心血於專業級的研究和發展，才能夠提供業界趨勢的創新產品。

質量至上、永不妥協

高質量對於堂瑩來說是最重要的堅持，在每一個流程中時時檢討質量管理與細節，為了就是要讓客戶能享有符合經濟效益的高質量解決方案。

長期合作關係

我們深信合作夥伴在各個階段都是可以與堂瑩一起互相成長。和事業夥伴保持良好的關係，是我們能夠不斷在各方面持續成功最主要的關鍵。

堅毅不拔

所有堂瑩的員工都有著共同努力的目標，並在壓力之中學習成長，勇于接受挑戰。藉由全公司上下努力不懈完成使命，期望每一個人都可以享受到科技創新所帶來的便利。我們通過有效的增長實現可持續的發展，並以平衡的業務組合為杠杆，實現跨地區及業務領域的整合效應，追求完美卓越，正是實踐對社會做出貢獻的承諾。

制動器、離合器、安全夾頭系列



目錄 CONTENTS

氣脹軸 安全夾頭系列 AIR SHAFT SAFETY CHUCK SERIES

KEY型鍵條式氣脹軸	KEY-TYPE AIR SHAFT WITH EXPANDING KEYS	2
LEA型板條式氣脹軸	LEA-TYPE AIR SHAFT WITH LEAVES	3
STR型鋁體通條式氣脹軸	STR-TYPE AIR SHAFT WITH EXPANDING STRIPS & ALUMINIUM BODY	4
STR型鋼體通條式氣脹軸	STR-TYPE AIR SHAFT WITH EXPANDING STRIPS & STEEL BODY	5
MCE型機械式氣脹軸	MCE-TYPE MECHANICAL AIR SHAFT	6
CFE型碳纖維氣脹軸	CFE-TYPE CARBON FIBER AIR SHAFT	6
SPS型滑差軸	SPS-TYPE DIFFERENTIAL AIR SHAFT	7
JAC型氣壓套夾	JAC-TYPE EXPANDING SLEEVE CHUCK	8
PNC型氣壓夾頭	PNC-TYPE EXPANDING CHUCK	9
ACR型弧形輥	ACR-TYPE ARC-SHAPED ROLLER	10
AIR型鋁導輥	AIR-TYPE HIGH-PRECISION ALUMINIUM IDLER ROLLER	11
NEA型旋轉式機械夾頭	NEA-TYPE ROTARY & MECHANICAL CHUCK	12
NED型旋轉式機械夾頭	NED-TYPE ROTARY & MECHANICAL CHUCK	13
NEB型側推式機械夾頭	NEB-TYPE SIDE-PUSHING MECHANICAL CHUCK	14
安全夾頭	SAFETY CHUCK	15-24
手動制動器	MANUAL BRAKE	25
滑動安全夾頭	SLIP SAFETY CHUCK	26-33
平推式安全夾頭	HORIZONTAL PUSHING TYPE SAFETY CHUCK	34-35
氣壓式安全夾頭	AIR PRESSURE TYPE SAFETY CHUCK	36-38
扭力限制器	TORQUE LIMITER	39
附錄	APPENDIX	40



鍵條式氣脹軸被設計成用于軸心收卷和單軸放卷方式，用以滿足客戶高強度的張力或扭矩的需求，同時也滿足可以承受高的料重。

通過單氣囊的膨脹，鍵膨脹，軸芯就會被夾緊。

氣脹軸中心管體可由鋼或鋁制成，鍵由鋼制成。

若客戶有特別要求，鍵也可用其他材料制成。

為滿足客戶的特別要求，我們可以按照客戶圖紙要求定制各種材質與表面處理的軸頭。

由于其獨特的夾式系統，氣囊可以在軸頭抽出后被輕鬆的更換，不需要采用特殊工具。

It is especially designed to wind at shaft core and unwind at single shaft in order to either meet customers' requirements for more higher tension and torque or bear more weighted materials.

From expanding of single air bag and expanding keys, shaft core will be clamped.

The central body is made from steel or aluminium; expanding keys are made from steel.

Expanding keys can be made from other materials under customers' special requirements.

To meet our customers' special requirements, according to the drawings, we can make shaft head with all kinds of materials and surface treatments.

Due to its unique clamp system, air bag can be replaced after withdrawing the shaft head without adopting special tools.

型式	Model	1 英寸 inch	2 英寸 inches	3 英寸 inches	4 英寸 inches	5 英寸 inches	6 英寸 inches	8 英寸 inches	10 英寸 inches	12 英寸 inches
未充氣時直徑	Non-swell diameter [mm]	24	49	74	98	124	149	200	250	300
充氣后直徑	Swell diameter [mm]	28-32	52-54	79-81	103-105	129-131	154-156	205-207	255-257	305-307
適用卷管內徑	Applicable roll inside diameter [mm]	26-30	50.5-52	75.5-78.5	99.5-103	126-128	152-154	202-204	252-254	302-304
鍵數量	Key number	3+3	3+3	3+3	4+4	4+4	5+5	6+6	6+6	6+6
主體重量 鋼體	Body weight Steel [kg/m]	7	12	19	29	37	52	78	118	180
主體重量 鋁體	Body weight Aluminium [kg/m]	4	7	10	17	22	32	50	80	130
最大承重 鋼體	Maximum load Steel [kg]	50	200	1100	1850	3350	3700	4500	5500	6500
最大承重 鋁體	Maximum load Aluminium [kg]	20	100	700	950	1500	1900	2500	3200	4000
最大轉矩	Maximum torque [Nm/m]	100	200	440	570	980	1600	2200	3000	4000

注：其它尺寸在允許範圍內可依據需求定制

Other kit inserts are available at customer's request



板條式氣脹軸可用于分條收卷和懸臂式單軸放卷，六片式設計可使支撐更平衡，且保護氣囊具有更長壽命。通過單氣囊的膨脹，板條膨脹，軸芯就會被夾緊。氣脹軸中心管體可由鋼或鋁制成，板條由鋁制成。為滿足客戶的特別要求，我們可以按照客戶圖紙要求定制各種材質與表面處理的軸頭。由于其獨特的夾式系統，氣囊可以在軸頭抽出后被輕鬆的更換，不需要采用特殊工具。



It is designed to wind at leaves separately and unwind at cantilevered single shaft. Six-pieces design can provide a more balanced supporting, and ensure longer life for air bag. From expanding of single air bag and leaves, shaft core will be clamped. The central body is made from steel or aluminium; leaves are made from aluminium. To meet our customers' special requirements, according to the drawings, we can make shaft head with all kinds of materials and surface treatments. Due to its unique clamp system, air bag can be replaced after withdrawing the shaft head without adopting special tools.

型式	Model	1 英寸 inch	2 英寸 inches	3 英寸 inches	4 英寸 inches	5 英寸 inches	6 英寸 inches
未充氣時直徑	Non-swell diameter [mm]	25	50	75	99	125	150
充氣后直徑	Swell diameter [mm]	27	52	78	102	130	158
適用卷管內徑	Applicable roll inside diameter [mm]	25.4-26	50.8-51.5	75.6-76.8	100-101	126-128	151-156
板條數量	Leaf number	2	3	6	8	5	6
主體重量 鋼體	Body weight Steel [kg/m]	7	14	18	28	36	51
主體重量 鋁體	Body weight Aluminium [kg/m]	3.5	6	9	16	21	31
最大承重 鋼體	Maximum load Steel [kg]	40	150	800	1500	2000	3000
最大承重 鋁體	Maximum load Aluminium [kg]	-	-	500	950	1300	2000
最大轉矩	Maximum torque [Nm/m]	100	200	520	1120	1330	2210

注：其它尺寸在允許範圍內可依需求定制 Other kit inserts are available at customer's request

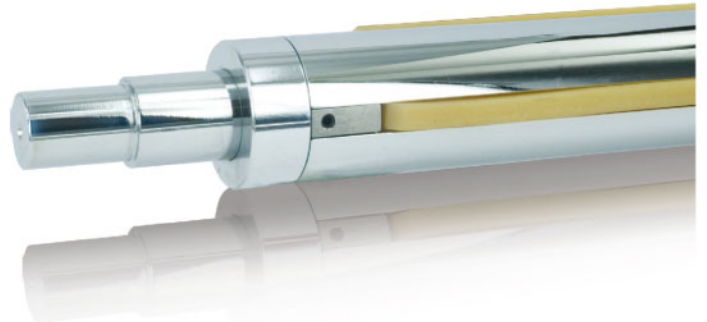

通長鍵條式氣脹軸，收放卷都可適用，多氣囊式設計，氣囊長度與氣脹軸主體相似。

主體材質可選鋼或鋁；鍵條材質可選橡膠，鋁或聚氨酯。根據用戶的特殊要求，可選其他材料。

鋼質軸頭是按客戶的圖紙生產，以滿足任何特殊的要求。

鋁合金主體標準尺寸與規格(見下表)，其他尺寸可應要求提供。

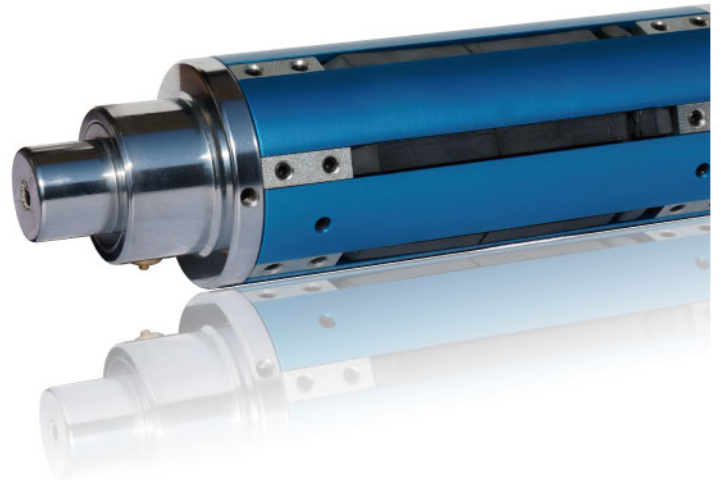

It applies to both winding and unwinding, and has the design of multiple air bags, in which their lengths are like that of air shaft body.

The central body is made from steel or aluminium; Strips can be made from rubber, aluminium, or polyurethane. They can be made from other materials under customers' special requirements.

Steel shaft head can be made according to customers' drawings, to meet any special requirements.

The aluminium alloy body has a standard size and specification (as shown in below chart), and other sizes are available upon request.

型式	Model	1 英寸 inch	2 英寸 inches	3 英寸 inches	4 英寸 inches	5 英寸 inches	6 英寸 inches	8 英寸 inches	10 英寸 inches	12 英寸 inches
未充氣時直徑	Non-swell diameter [mm]	25	50	74.5	99	125	150.4	201	252	302
充氣后直徑	Swell diameter [mm]	27	52.8	77.5	102	128	154.4	205	256	306
適用卷管內徑	Applicable roll inside diameter [mm]	25.4	50.8	76.2	101.6	127	152.5	203.2	254	304.8
鍵數量	Key number	3	3	6	6	6	6	8	8	8
主體重量 鋁體	Body weight Aluminium [kg/m]	2.6	4.9	9.5	15.3	16.5	20.7	33	50	80
最大承重 鋁體	Maximum load Aluminium [kg]	20	100	700	1200	2200	3000	4000	5000	6000
最大轉矩	Maximum torque [Nm/m]	100	200	620	1120	1330	2210	2920	3500	4800

注：其它尺寸在允許範圍內可依需求定制 Other kit inserts are available at customer's request

獨特的氣脹軸設計，氣囊和通長鍵條可以很容易的更換，而不必拆卸軸頭。

通氣使氣囊膨脹時，氣脹軸通長鍵條外徑得以擴大，卡住紙管內徑。

鋼質主體標準尺寸與規格(見下表)，其他尺寸可應要求提供。

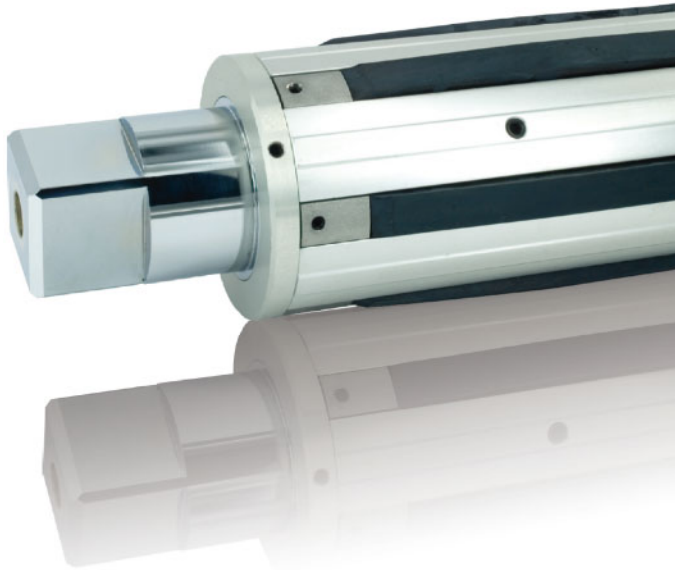

Thanks to the exclusive design of air shaft with key strips, air bag and expanding strips are easily to replace without having to dismantle the shaft head. When air bag swells by air, the outside diameter of air shaft' s expanding strips expands to get stuck with inside diameter of paper tube.

The steel body has a standard size and specification (as shown in below chart), and other sizes available upon request.



型式	Model	1 英寸 inch	2 英寸 inches	3 英寸 inches	4 英寸 inches	5 英寸 inches	6 英寸 inches	8 英寸 inches	10 英寸 inches	12 英寸 inches
未充氣時直徑	Non-swell diameter [mm]	25	50	74.5	99	125	150.4	201	252	302
充氣后直徑	Swell diameter [mm]	27	52.8	77.5	102	128	154.4	205	256	306
適用卷管內徑	Applicable roll inside diameter [mm]	25.4	50.8	76.2	101.6	127	152.5	203.2	254	304.8
鍵數量	Key number	3	3	6	6	6	6	8	8	8
主體重量 鋼體	Body weight Steel [kg/m]	3.5	15	35	56	81	127	195	295	450
最大承重 鋼體	Maximum load Steel [kg]	60	300	1300	1900	3400	3800	5000	6000	7000
最大轉矩	Maximum torque [Nm/m]	100	200	620	1120	1330	2210	2920	3500	4800

注：其它尺寸在允許範圍內可依據需求定制

Other kit inserts are available at customer's request

機械式氣脹軸主要應用於對動平衡有要求的場合；可適應高轉速應用場合；產品具備了整體高同心度的性能，對於料卷轉動的跳動有較好控制；在需要精確定位的場合，也有優異的表現。

工作原理在於帶有斜面的活塞，壓縮空氣進入氣室，推動活塞軸向運動；帶動帶有斜面的鍵條進行徑向運動，鍵條擴展，卡緊料管；所有的鍵條同步擴展，到達一個相同的高度，優勢是絕對同心。



Mechanical air shaft is mainly applied to some occasions that require dynamic balance; It can be used in high rotation speed; It has property of high concentricity in whole structure and has better control in bounces of roll; It also has excellent performance in accurate positioning occasions.

The functional principle is based on piston with inclined plane; By feeding compressed air into air chamber, piston is pushed to an axial movement; And also rotates key strips with inclined plane to a radial movement, so key strips will expand to clamp material pipe; All key strips will expand simultaneously to the same height with the advantage of absolute concentricity.

注：其它尺寸在允許範圍內可依據需求定制 Other kit inserts are available at customer's request

CFE 型碳纖維氣脹軸

CFE-TYPE CARBON FIBER AIR SHAFT

碳纖維氣脹軸僅為傳統氣脹軸 1/4 的重量，非常適合高承載及需人力搬運上、下料使用。

可減輕操作人員在搬運上的職業傷害，更可提高工作效率，具備了最佳人體工程學優點和極其出色的性能。

最優化的內部結構設計更加代表了氣脹軸產業的未來，即使在高轉速領域，也不會產生劇烈震動。

強度最優比例的斷面模量，更是廣泛適用於各種應用需求；特殊的表面處理在各種特殊環境（無塵、腐蝕性、高溫環境下）皆可適用。



The weight of CFE-type carbon fiber air shaft is just 1/4 of traditional one. And CFE-type carbon fiber air shaft is very suitable to use in high load capacity and manual loading and unloading situations.

It can reduce most the operation staffs' occupational injuries on transportation and improve their work efficiency, with the advantage of the best ergonomics and performance.

Optimized design of internal structure much represents the future of air shaft industry, even if in high-speed field, it won't produce severe shock.

It has section modulus in best intensity ratio, which can be applied to all kinds of requirements. Special surface treatment fits to all kinds of special environments (dust-free, corrosivity, high temperature situations).

注：其它尺寸在允許範圍內可依據需求定制 Other kit inserts are available at customer's request



滑差式氣脹軸主要應用於收卷軸，特殊場合也用於放卷軸。

產品本體由鍍鉻鋼或硬氧化鋁制作，摩擦條可用聚氨酯、聚乙烯或橡膠材料制作，具體依據最大張力要求而定。

為滿足客戶的特別要求，可以按照客戶圖紙要求制定不同尺寸的鋼軸頭。

當塑料膜或其它材質放卷時，材料的厚度會有差異。在不斷收卷過程中，這種差異會導致明顯的料卷外徑差異，在這種情況下，所需的繞卷扭矩會稍有不同。

在幾次繞卷旋轉後，一些料卷可能會變得很緊，同時其他料卷會開始鬆弛，最終使產品的質量下降。

我們的滑差式氣脹軸可以保證最高料卷質量，通過在卷軸運行時保持所有料卷適當的張力，材料將不會產生問題。

工作原理在於滑差環在氣脹軸中心持續滑動，為保證張力一致，一些軸環會較其他軸環滑動更快。從而精確地控制每一卷材料的張力，得以恒張力卷取，保證了料卷質量。

根據不同的軸徑，為了控制氣囊中的氣壓和保證張力，需要用旋轉式接頭來恒定氣壓來源。

It is applied mainly to wind shaft, or unwind shaft in special occasions.

The body is made from chrome-plate steel or hard anodized aluminium. The friction plate can be made from polyurethane, polyethylene, or rubber to max. tension required.

To meet our customers' special requirements, according to the drawings, we can make steel shaft head with different sizes.

Difference in material thickness often arises when unwinding plastic films or other materials. In the process of constant winding, this difference can lead to obvious discrepancy in outside diameter of roll, and slight discrepancy in winding torque under this situation.

After some winding rotations, some rolls may become very tight, and meanwhile, some other rolls may start to loosen, leading to quality decline in product eventually.

Our differential air shaft with slipping friction can ensure the highest winding quality, and by keeping proper tension on all rolls throughout the winding operation, materials will not show any problem.

It works under the theory that friction rings slip constantly in center of air shaft, and to keep same tension, some rings slip faster than others. So tension of each roll can be controlled accurately, and permanent tension can also be gained to guarantee the quality of roll.

According to different roll diameters, to control air pressure of air bag and to guarantee tension, a constant air pressure source kept by rotary joint is required.

適用卷管內徑	Applicable roll inside diameter [mm]	50,8	70	76,2	152,4
未充氣時直徑	Non-swell diameter [mm]	50	69	75	151,5
重量 不含軸頭	Weight journals not included [Kg x m]	12	27	32	61
最大轉矩	Maximum torque [Nm/m]	21	29	32	64

注：其它尺寸在允許範圍內可依據需求定制 Other kit inserts are available at customer's request

氣脹套夾是安裝在現成的氣脹軸上，定位在氣脹軸末端的部件，主要用于 3 英寸氣脹軸轉 6 英寸料卷時使用。
 可用 3 英寸氣脹軸本身的抓力對本套夾內徑加以固定，或以附屬的弧形迫環固定。
 產品本體和弧形迫環由鋁制成，氣脹的部分由橡膠制成。
 通孔可以根據客戶要求制定。
 我們的氣脹套夾可以串聯連接。
 氣脹套夾適用於短暫替代用，長期使用時建議以 6 英寸軸為佳。



It is fixed onto ready-made air shaft, positioned at the end of air shaft, mainly applied to 3-inches air shaft and 6-inches rolls.
 We can use 3-inches air shaft, in its own grabbing force to fix the inside diameter of expanding sleeve chuck, or using possessed arc-shaped rings.
 The body and arc-shaped rings are made from aluminium, and the expanding part is made from rubber.
 The through hole can be customized by requirements.
 Our expanding sleeve chuck can be linked in series.
 It is fit to work transiently, and 6-inches air shaft is recommended for long-time use.

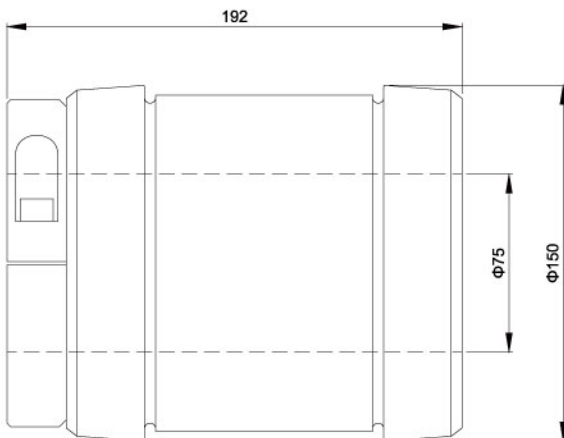

JAC603

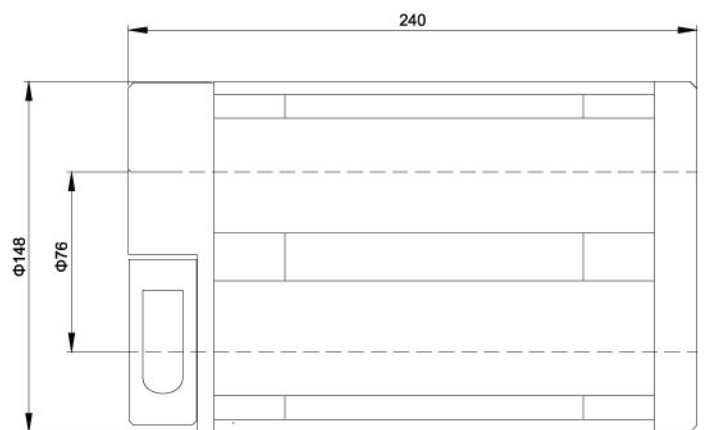

JAC609

注：其它尺寸在允許範圍內可依據需求定制 Other kit inserts are available at customer's request

氣脹夾頭是屬於自動定心的機械式氣脹軸。
 利用法蘭安裝在料架端面上，可以替代普通氣脹軸，在需要軸的最佳中心定位時，這種夾頭是理想的解決方案。可以達到傳送高扭矩值或高速工作的目的地，在高轉速運行時震動極小。

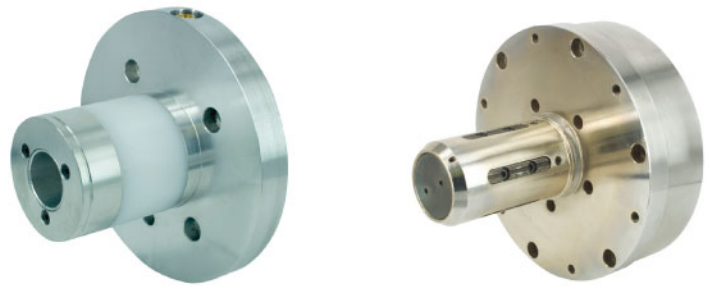

It belongs to self-centering mechanical air shaft.
 And it is mounted onto rack end surface and can replace common air shaft. It is an ideal solution when an optimized centering of roller is required.
 It can reach the goal of high torque value and working at high speed without shaking too strongly.

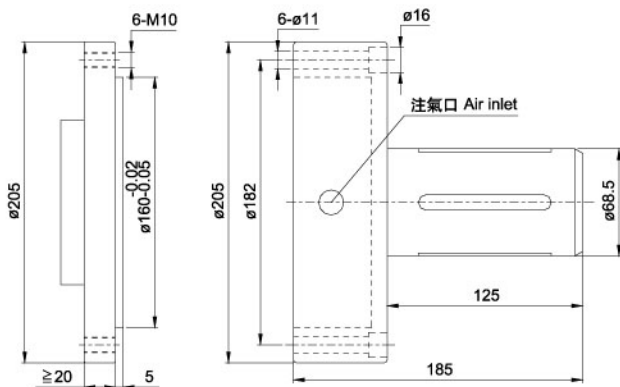

氣壓	Air pressure [Mpa]	0.8
最大承重	Maximum load weight [Kg]	1000
最大轉矩	Max torque [kgf/m]	45
脹氣直徑	Air expanding diameter [mm]	68.5-80
卷內直徑	Roll inside diameter [mm]	70-76.2

PNC夾頭用NF適配器

氣脹夾頭轉直徑適配器，用于無軸料卷的上下料。

PNC Chucks With NF Adaptors

The self-centring chucks and diameter adaptors are used for shaft-less unwinding and winding operations.

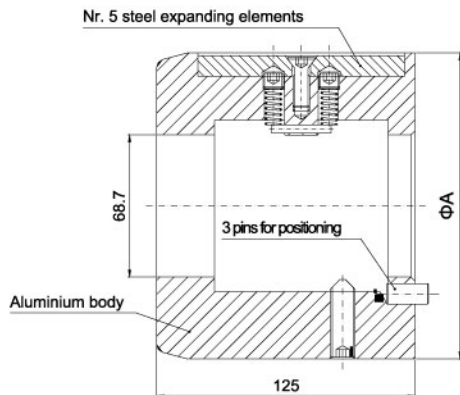

適配器	Adaptor	NF4	NF5	NF6
直徑	Diameter A [mm]	98,5	125	148
最大轉矩	Max torque [kg mt]	60	65	80
膨脹直徑	Diameter expansion [mm]	da 98,5 a 104	da 125 a 130	da 148 a 155
內徑	Inside core diam.	101,6 (4")	127 (5")	152,4 (6")

注：其它尺寸在允許範圍內可依據需求定制 Other kit inserts are available at customer's request

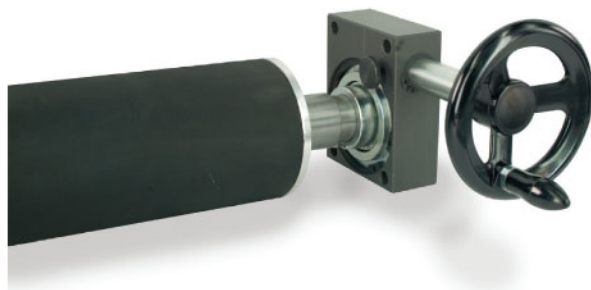

當加工紙質、布料或者塑料薄膜時，爲了防止材料打皺、產生折縫，弧形輥被用來均勻地傳遞材料來達到展平的效果。

產品表面采用油性防靜電黑色橡膠，具有優良的機械性及耐磨性，若客戶有使用上的特殊要求，也可以采用其他種類橡膠。

所有種類的輥都可以軸座固定或采用法蘭固定。

弧形輥的標準弧度是標準直徑的 1% 到 1.4%。

Arc-shaped roller is used to deliver materials uniformly to achieve flattening effect, so that when to process paper, cloth, or plastic film, materials will not have wrinkles and creases.

It is coated with antistatic black rubber, having excellent mechanical and wearproof features.

Other rubber types can be adopted for special using requirements.

All kinds of rollers can be foot-mounted or flange-mounted.

Arc-typed roller's standard radian is 1%-1.4% of standrad diameter.

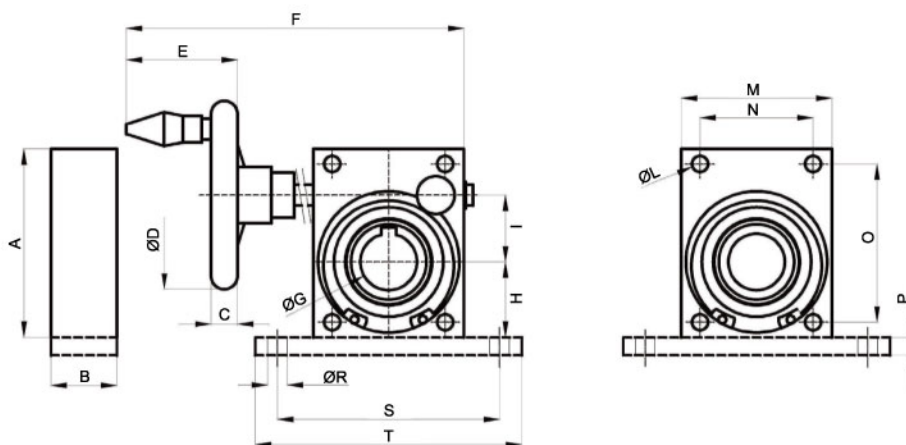

型式 Model	A	B	C	ØD	E	F	ØG	H	I	ØL	M	N	O	P	ØR	S	T
SG1 SP1	100	35	15	100	61	230	25	40	35,5	8,5	80	60	84	10	11	125	150
							30										
SG2 SP2	140	50	15	120	61	250	35	69	41	10,5	120	100	120	20	13	160	200
							40										
SP3 SG3	138	60	15	120	61	250	50	69	53	8	130	110	67,5	20	13	170	210



型式 Model		ACR075	ACR085	ACR100	ACR130	ACR150
軸徑 Roller Ø		75	85	100	130	150
主體尺寸 Body size	最小 min	500	500	1400	1400	1400
	最大 max	1800	2000	3000	4000	4000
支持類型 Support Type		SG1-SP1	SG1-SP1	SG2-SP2	SG2-SP2	SG3-SP3

注：其它尺寸在允許範圍內可依據需求定制

Other kit inserts are available at customer's request

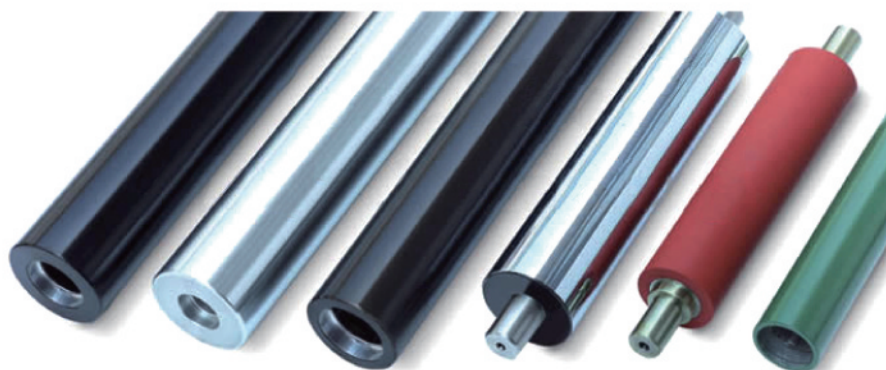

高精度鋁導輥

STEKI 鋁合金導輥具有單位强度高、質輕、慣量小、表面光亮不生銹等優點，廣泛應用於凹凸版印刷、塗布、覆卷、吹膜、貼合、鍍膜、分切、造紙、紡織等生產線。

STEKI 所生產的鋁合金導輥經過最嚴格的原料擠壓生產流程，高强度的特殊截面與加強筋可大幅提升鋁管剛性，優良的熱套裝配工藝與數控車床的表面精車可使產品獲得最高結合強度與精度，良好的直線性與同心度，精確高速的動平衡系統可同時確保靜平衡與高速動平衡性能（可達到 ISO1940 G1 等級），確保鋁輥在機器上高速運轉不產生振動，而不同的表面處理方式可提供不同的使用需求，STEKI 所生產的鋁輥可大幅提升您機器的性能。

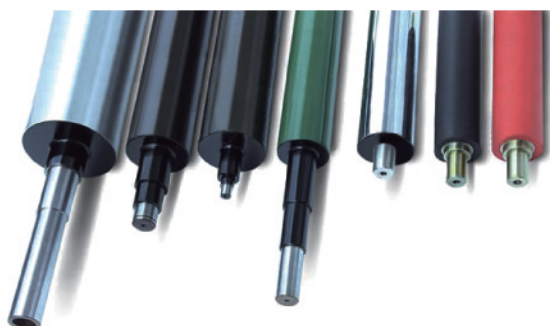

High-precision Aluminium Idler Roller

Characterized by high unit strength, light weight, small inertia, bright and anti-rusty surface, aluminium idler roller is widely applied for rotogravure printing, coating, rewinding, film blowing, laminating, slitting, paper making, textile and other production lines.

The aluminium idler roller produced by STEKI has gone through the strictest raw materials extrusion production process. The high-strength special-section and ribs inside can significantly enhance the rigidity of the aluminium tube. The excellent shrink fitted assembly procedure and the surface tooling by the CNC lathe can enable the product to obtain the highest combination strength and accuracy, good linearity and concentricity. The precision high-speed dynamic balancing system can simultaneously ensure both the static balance and the high-speed dynamic balance performance (G1 grade of ISO1940) so as to avoid any vibration of the aluminium idler roller in high-speed operation. The various kinds of surface finish can meet requirements of various purposes. To sum up, the aluminium idler roller of STEKI can significantly enhance the performance of your machines.

帶加強筋鋁管毛胚尺寸 Raw size of aluminium roller with reinforcing rib

外徑	Out diameter [mm]	Φ228	Φ181.7	Φ152	Φ147	Φ131.2	Φ131.5	Φ121.2	Φ114.5
內徑	Inside Diameter [mm]	Φ210	Φ160	Φ140	Φ130	Φ120	Φ116	Φ111	Φ102
加強筋	Ribs Amount x radius [mm]	10條 x R8	9條 x R5	8條 x R5	9條 x R5	8條 x R4.5	8條 x R4.5	8條 x R4.5	8條 x R4.5

外徑	Out diameter [mm]	Φ111.3	Φ101.2	Φ101.3	Φ96	Φ91.2	Φ89	Φ88.2	Φ81.2
內徑	Inside Diameter [mm]	Φ101	Φ92	Φ86	Φ84	Φ82	Φ77	Φ79	Φ72
加強筋	Ribs Amount x radius [mm]	8條 x R4.1	8條 x R4.1	9條 x R4.5	9條 x R4.5	8條 x R4.1	8條 x R4.5	8條 x R4.1	8條 x R4.1

外徑	Out diameter [mm]	Φ76.2	Φ75.4	Φ71.2	Φ63.2	Φ61.2	Φ56	Φ52	Φ51
內徑	Inside Diameter [mm]	Φ67	Φ64	Φ62	Φ52	Φ50	Φ46	Φ40	Φ40
加強筋	Ribs Amount x radius [mm]	8條 x R4.1	8條 x R4	8條 x R4.1	8條 x R4	8條 x R4	8條 x R4	8條 x R4	8條 x R4

注：其它尺寸在允許範圍內可依據需求定制 Other kit inserts are available at customer's request

夾頭種類很多,細分各有其用途。

夾頭廣泛用於捲取和放料的各種機械上,此旋轉迫緊夾頭是運用簡單的滑動原理,使扇形結構擴張固定料管并自動對心,這種夾頭使得料管可多次重複使用,以減少料管損失。

There are many kinds of chucks for different applications.

They are applied widely to various winding or unwinding machines. This rotary packing chuck adopts simple sliding principle that fanshaped structure expands to fix roll and aligns automatically, which can make roll multi-repeat use and reduce its wearout.

規格表

型號	Model	NEA3
最大承重	Max load bearing [Kg]	1200
脹氣直徑	Swell diameter [mm]	75-85
卷內直徑	Roll diameter [mm]	76-80

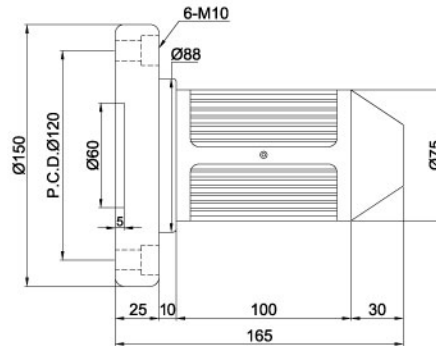

規格表

型號	Model	NEA6
最大承重	Max load bearing [Kg]	4000
脹氣直徑	Swell diameter [mm]	150-157
卷內直徑	Roll diameter [mm]	151-155

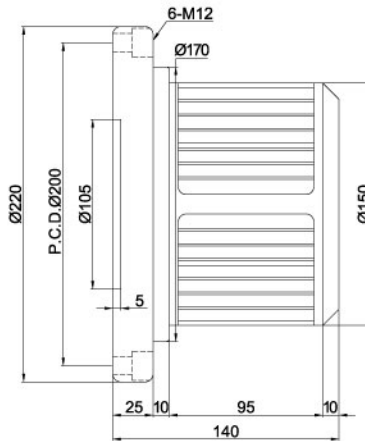

規格表

型號	Model	NEA36
最大承重	Max load bearing [Kg]	1200;4000
脹氣直徑	Swell diameter [mm]	75-79;150-157
卷內直徑	Roll diameter [mm]	76-78;151-152

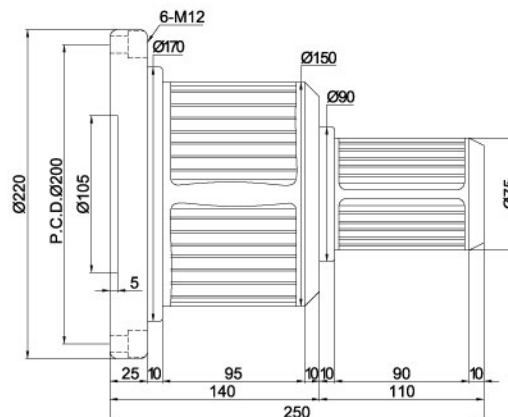

注: 其它尺寸在允許範圍內可依需求定制

Other kit inserts are available at customer's request

原紙架專用機械式夾頭

傳統的錐形夾頭，在使用過程中存在破損原紙紙芯的弊端，使用新型機械式自動定心夾頭，可提高原紙利用率，降低生產成本。

免維護，應用特殊材質，耐磨損，長壽命。

高扭矩，高承重，多款尺寸選擇。

Shaft-less Winders Exclusive Mechanical Chuck

Traditional tapered chuck may damage the paperboard core in use procedure, while using our new mechanical & automatic centring chuck can improve raw paper use ratio and reduce production cost.

It is maintenance-free with special texture, wear resistance and long service life.

Besides, it has high torque and load capacity, different sizes for you to choose from.

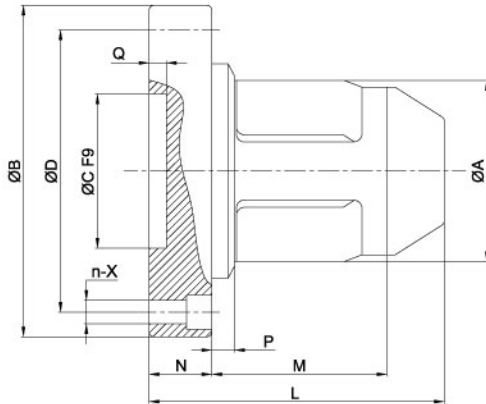

型式 Model	A	B	C	n-X	D	L	M	N	P	Q	重量(約) Weight	最大擴幅 Max. expanding	最大承重 Max. load bearing	轉矩 Torque [Nm]
NED-3	75	195	90	6-13.5	166	164.5	104.5	37	13.5	10	12kg	85	1.8	1150
NED-4	100	195	90	6-13.5	166	175	104.5	37	13.5	10	15kg	110	2.5	2500
NED-5	127	220	90	6-13.5	190	175	104.5	37	13.5	10	21.5kg	137	3.5	2500
NED-6	151	250	110	6-13.5	220	165	104.5	37	13.5	10	28.5kg	161	4.5	5000
NED-12	303	390	150	6-18.5	350	175	104.5	45	13.5	10	50kg	313	11	16000

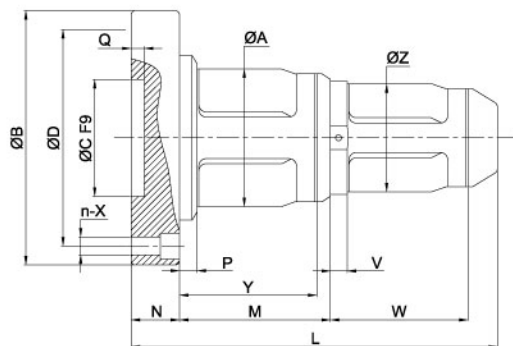

型式 Model	A	Z	B	C	n-X	D	L	Y	N	P	Q	M	W	V	重量(約) Weight	其他參數 Other parameters
NED-34	100	75	195	90	6-13.5	166	280	104.5	37	13.5	10	115.5	104.5	13.5	18kg	同上 Dmm
NED-35	127	75	220	90	6-13.5	190	280	104.5	37	13.5	10	115.5	104.5	13.5	24kg	同上 Dmm
NED-45	127	100	220	90	6-13.5	190	290.5	104.5	37	13.5	10	115.5	104.5	13.5	27kg	同上 Dmm
NED-36	151	75	250	110	6-13.5	220	280	104.5	37	13.5	10	115.5	104.5	13.5	40kg	同上 Dmm
NED-612	303	151	390	150	6-18.5	350	290.5	104.5	45	13.5	10	115.5	104.5	13.5	70kg	同上 Dmm

注：其它尺寸在允許範圍內可依需求定制

Other kit inserts are available at customer's request

液壓紙架最適合之側推式夾頭。

液壓支臂移動側推時,使扇形結構擴張固定料管并自動對心。

較大的接觸面積,對料管無損傷。

多規格,高承重,免維護,長壽命,操作簡便,減少繁重搬運而引起的風險。

Hydraulic pressure paper holder is most suitable to side-pushing mechanical chuck.

When hydraulic support arm is moved and pushed from side, fanshaped structure expands to fix roll and aligns automatically.

Large touching area can prevent roll from damage.

It has more specifications, high load bearing, maintenance free, long life, simple operation, and reduces risks from heavy handling.

規格表

型號	Model	NEB3
最大承重	Max load bearing [Kg]	1500
脹氣直徑	Swell diameter [mm]	75-85
卷內直徑	Roll diameter [mm]	76-80

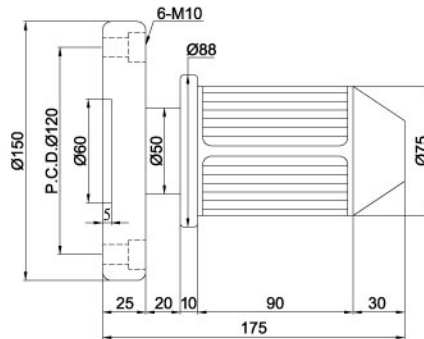

規格表

型號	Model	NEB6
最大承重	Max load bearing [Kg]	4000
脹氣直徑	Swell diameter [mm]	150-160
卷內直徑	Roll diameter [mm]	151-155

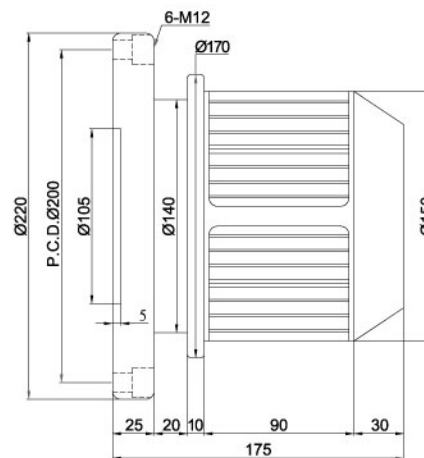

規格表

型號	Model	NEB36
最大承重	Max load bearing [Kg]	1500;4000
脹氣直徑	Swell diameter [mm]	75-83;150-157
卷內直徑	Roll diameter [mm]	76-80;151-155

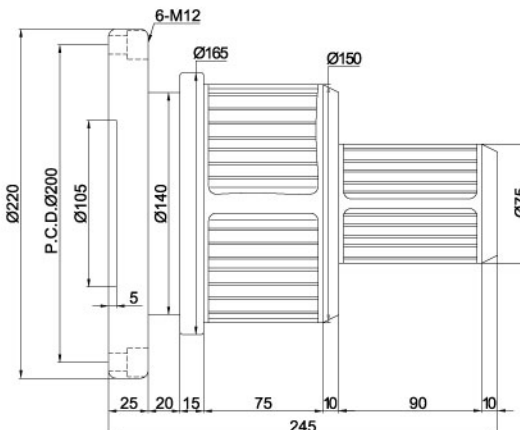

注: 其它尺寸在允許範圍內可依據需求定制

Other kit inserts are available at customer's request

FLO/FLW、STO/STW



安全夾頭為連結傳動及脫離動作之頻繁者，(提供快速、確實、簡易及安全的聯軸器)。
 精確的加工精度保證定位的準確。
 卷軸托口採用特殊的熱處理工藝。
 提供可更換 VT 型卷軸托口，更極大的延長了使用壽命。

Safety chuck can work frequently to link rotation or release action, providing fast, real, simple and secure coupling.
 Exact machining precision can ensure accurate positioning.
 Reel holding mouth adopts a special heat treatment technology.
 Replaceable VT-type reel holding mouth can be provided, which will extend greatly its service life.

標準型卷軸托口

Standard type reel holding mouth

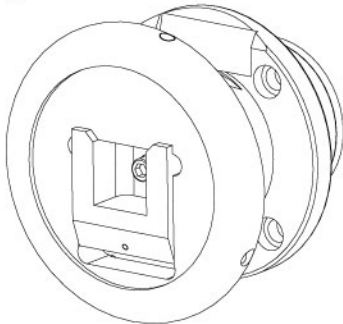

可更換型卷軸托口-VT

Replaceable VT-type reel holding mouth

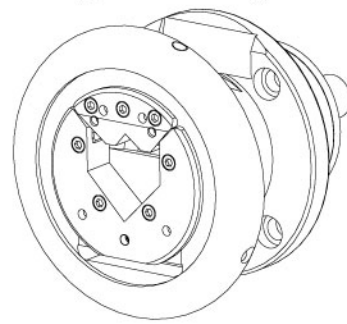

平推型圓形卷軸托口-RD

Horizontal pushing type round reel holding mouth-RD

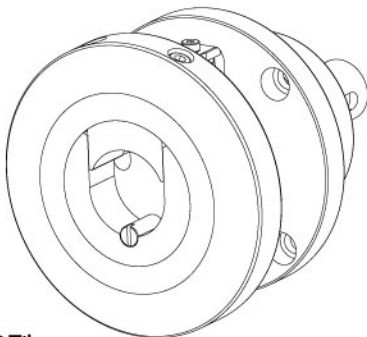

斜推型圓形卷軸托口-RD

Slanting pushing type round reel holding mouth-RD

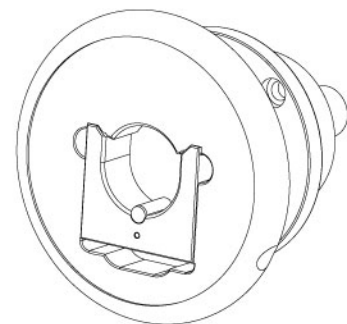

標準無軸O型

Standard O-type without shaft

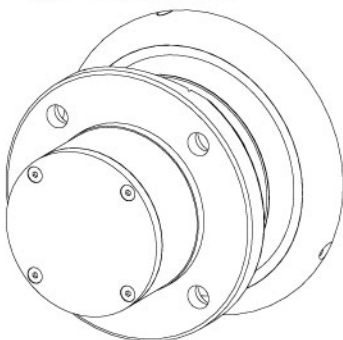

標準有軸W型

Standard W-type with shaft

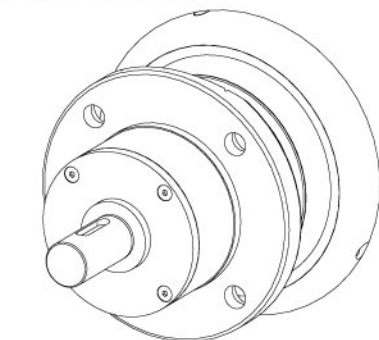

注：軸端尺寸在允許範圍內可依據需求定制

Other kit inserts are available at customer's request

法蘭型、軸座型安全夾頭 Flange type and pedestal type safety chuck

型號	Model	FLO/FLW 28-	STO/STW 28-
梁最大荷重量	Maximum load weight [kg]	800	800
承受最大轉矩	Withstand the maximum torque kg/m[N/m]	18(180)	18(180)
卷軸軸端允許尺寸	Reel end permissible size [mm]	22-30	22-30
重量 (約)	Weight [kg]	18	18

STO/STW 28

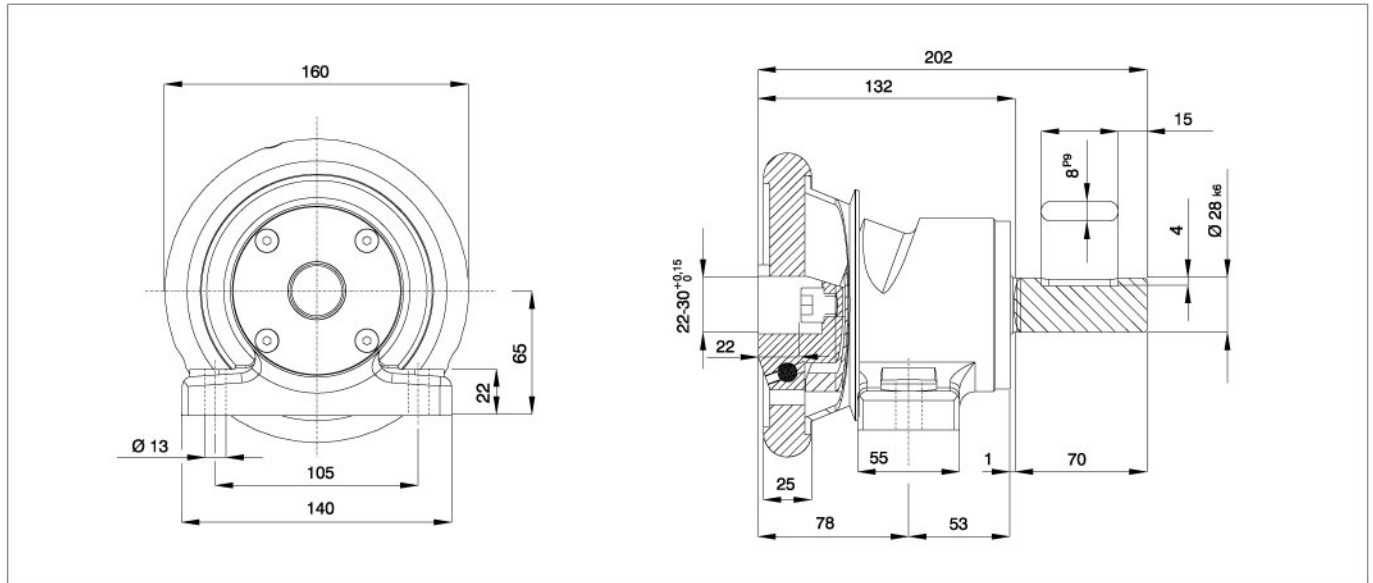

FLO/FLW 28

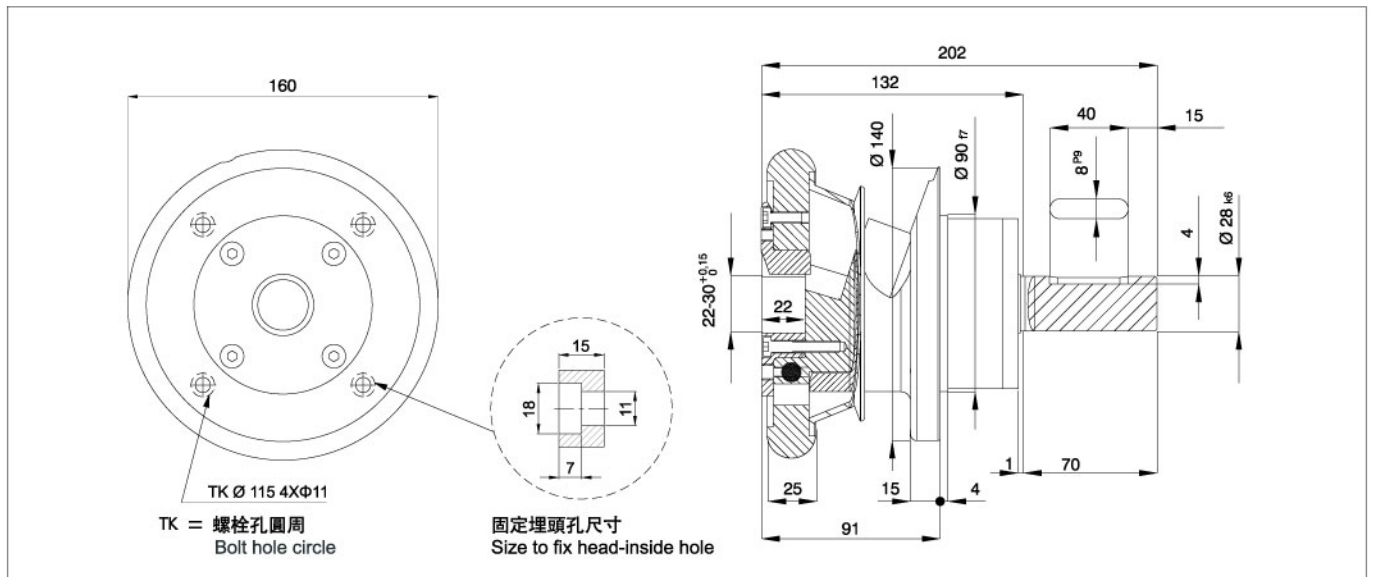

注：軸端尺寸在允許範圍內可依需求定制 Other kit inserts are available at customer's request

法蘭型、軸座型安全夾頭 Flange type and pedestal type safety chuck

型號	Model	FLO/FLW 35-	STO/STW 35-
梁最大荷重量	Maximum load weight [kg]	1600	1600
承受最大轉矩	Withstand the maximum torque kg/m[N/m]	35 (350)	35 (350)
卷軸軸端允許尺寸	Reel end permissible size [mm]	30-40	30-40
重量 (約)	Weight [kg]	25	25

STO/STW 35

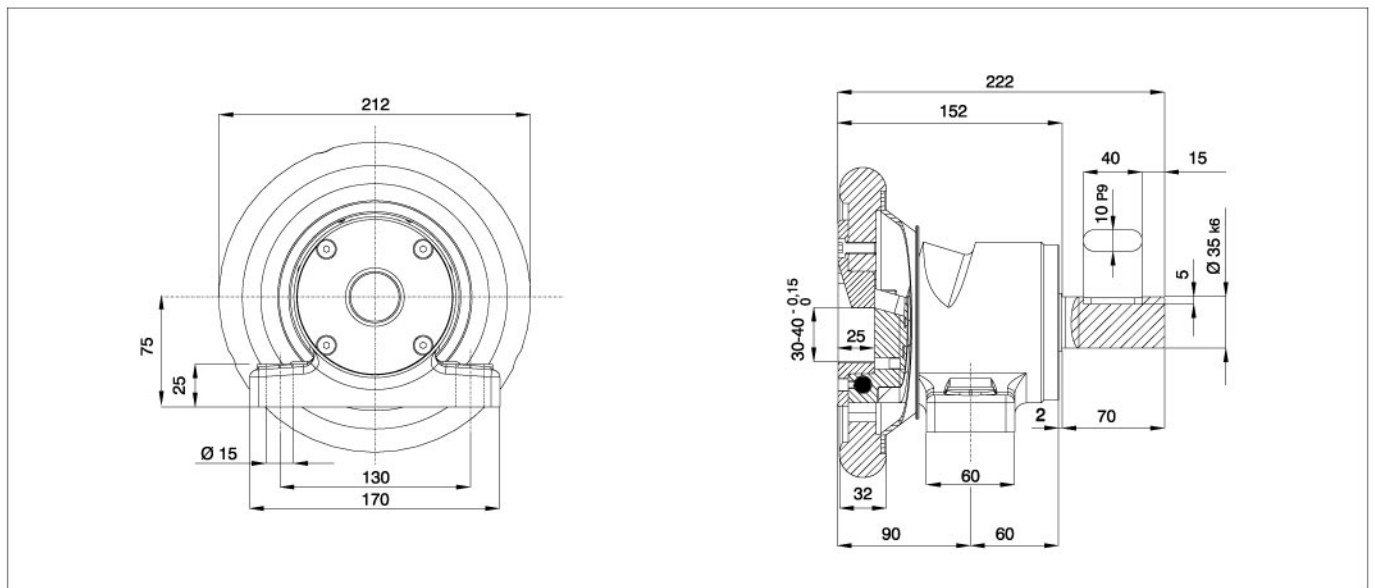

FLO/FLW 35

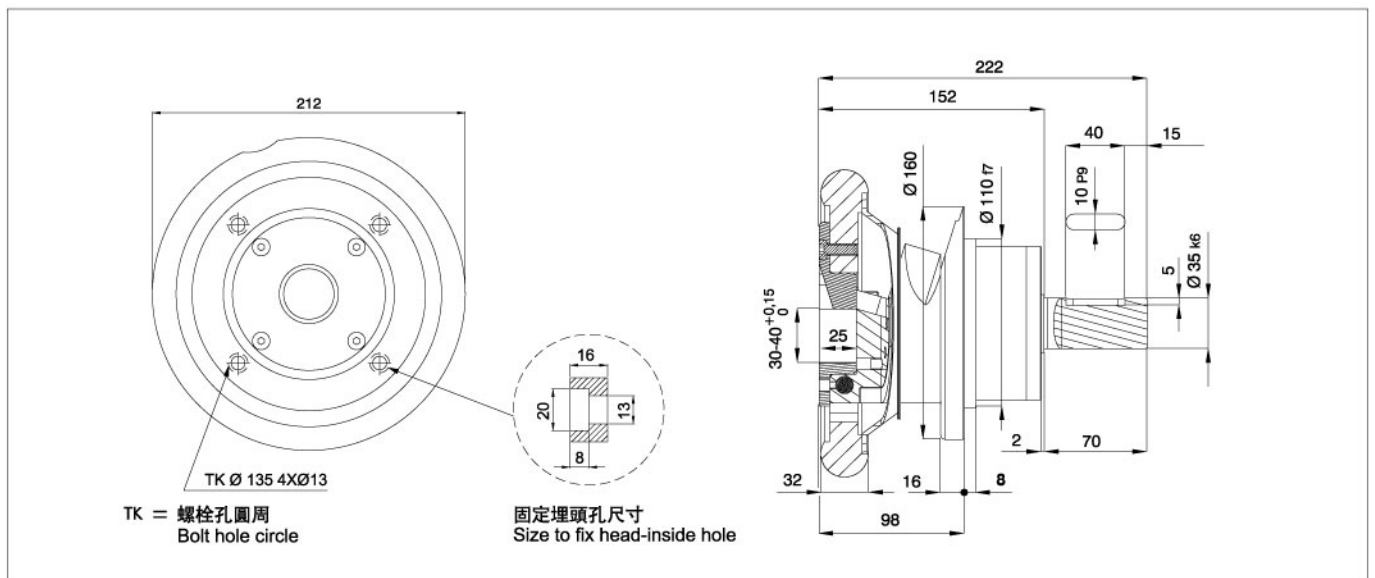

注：軸端尺寸在允許範圍內可依需求定制 Other kit inserts are available at customer's request

法蘭型、軸座型安全夾頭 Flange type and pedestal type safety chuck

型號	Model	FLO/FLW 50-	STO/STW 50-
梁最大荷重量	Maximum load weight [kg]	2800	2800
承受最大轉矩	Withstand the maximum torque kg/m[N/m]	110(1100)	110(1100)
卷軸軸端允許尺寸	Reel end permissible size [mm]	40-50	40-50
重量 (約)	Weight [kg]	50	50

STO/STW 50

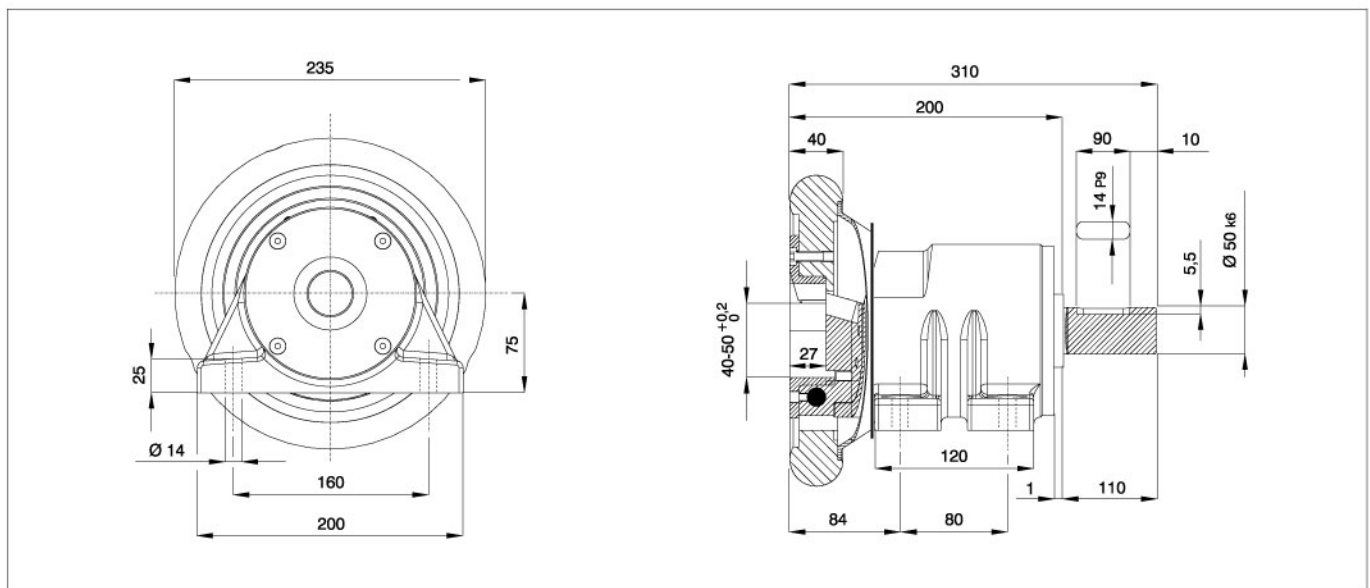

FLO/FLW 50

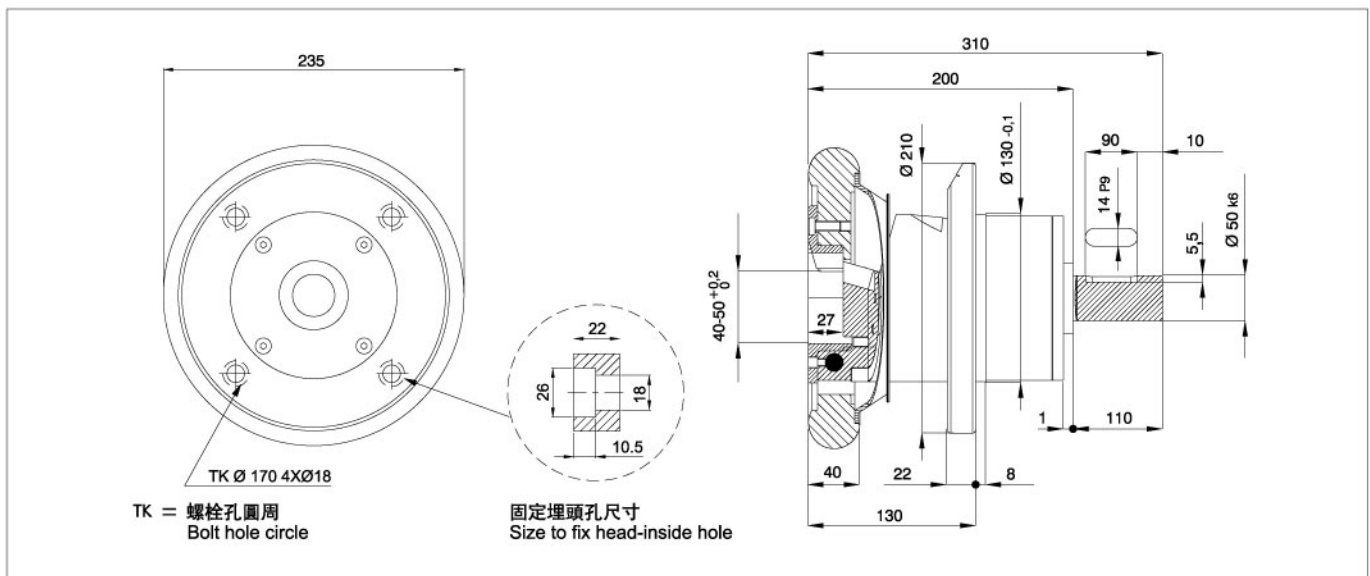

注：軸端尺寸在允許範圍內可依需求定制

Other kit inserts are available at customer's request

法蘭型、軸座型安全夾頭 Flange type and pedestal type safety chuck

型號	Model	FLO/FLW 75-	STO/STW 75-
梁最大荷重量	Maximum load weight [kg]	7000	7000
承受最大轉矩	Withstand the maximum torque kg/m[N/m]	235 (2350)	235 (2350)
卷軸軸端允許尺寸	Reel end permissible size [mm]	50-80	50-80
重量 (約)	Weight [kg]	85	85

STO/STW 75

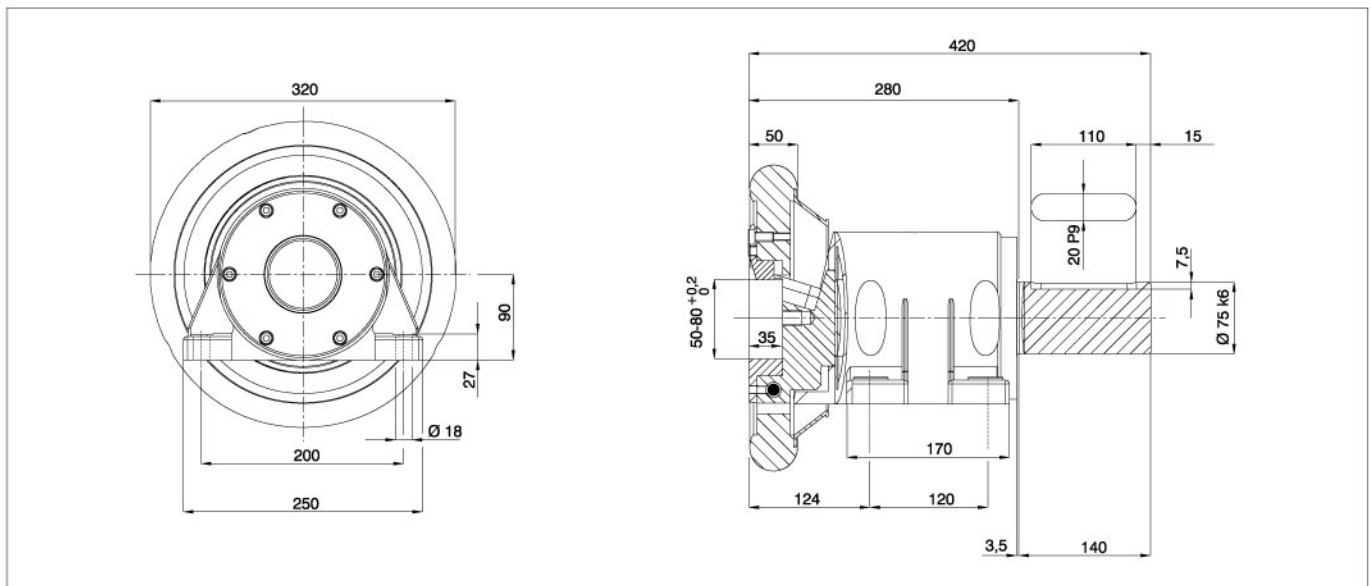

FLO/FLW 75

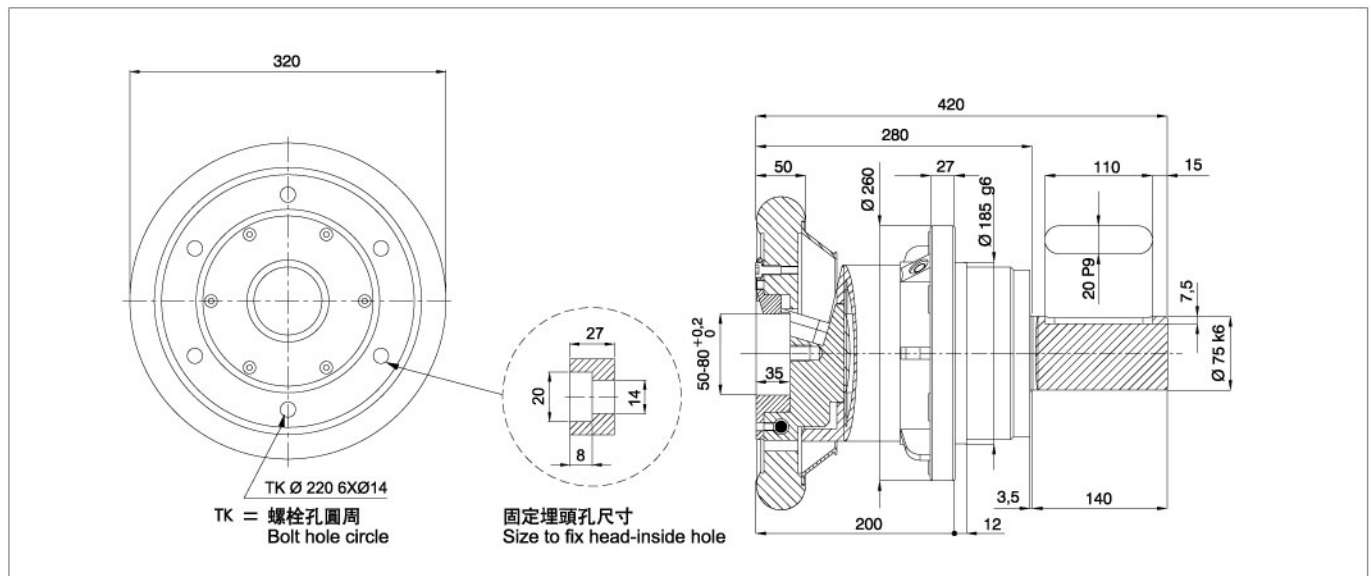

注：軸端尺寸在允許範圍內可依需求定制 Other kit inserts are available at customer's request

法蘭型、軸座型安全夾頭 Flange type and pedestal type safety chuck

型號	Model	FLO/FLW 110	STO/STW 110
梁最大荷重量	Maximum load weight [kg]	12000	12000
承受最大轉矩	Withstand the maximum torque kg/m[N/m]	1000(10000)	1000(10000)
卷軸軸端允許尺寸	Reel end permissible size [mm]	80-120	80-120
重量 (約)	Weight [kg]	200	200

STO/STW 110

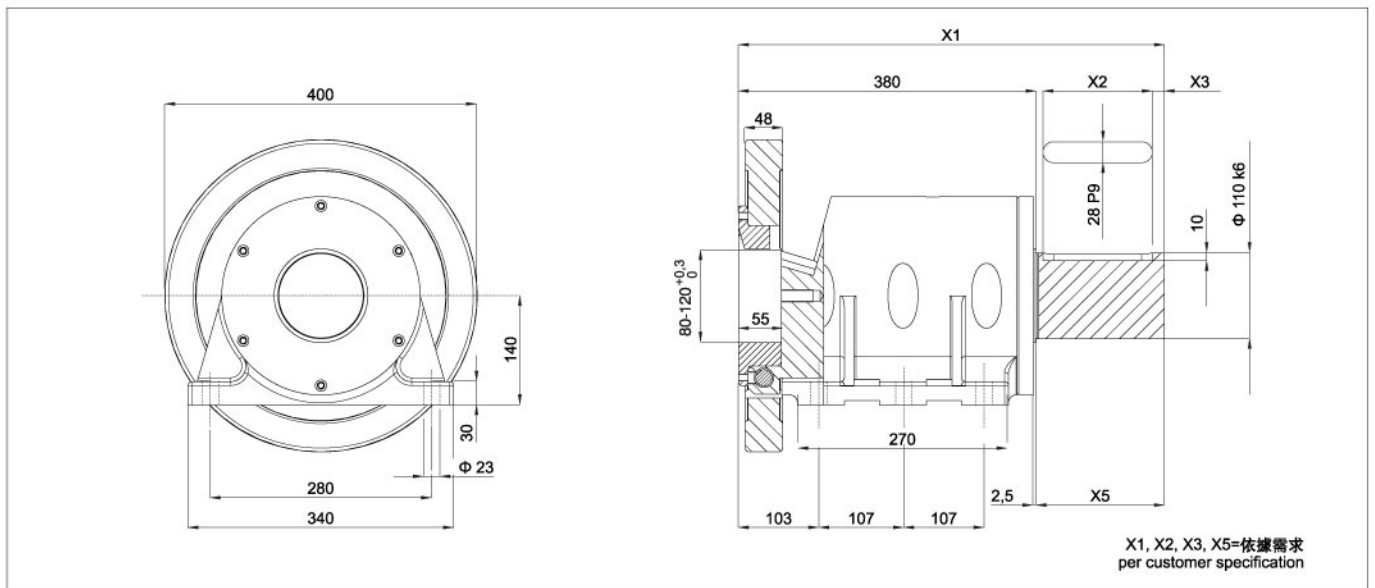

FLO/FLW 110

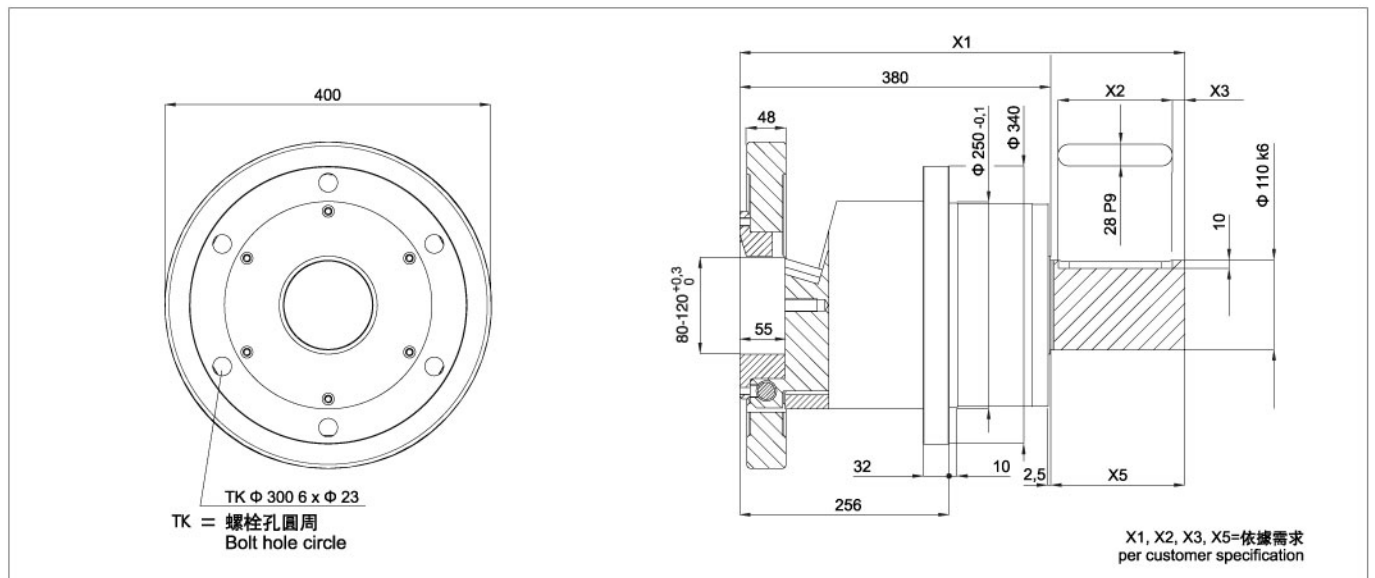

注：軸端尺寸在允許範圍內可依據需求定制 Other kit inserts are available at customer's request

VT型托口標準尺寸表 VT-type holding mouth standard size table

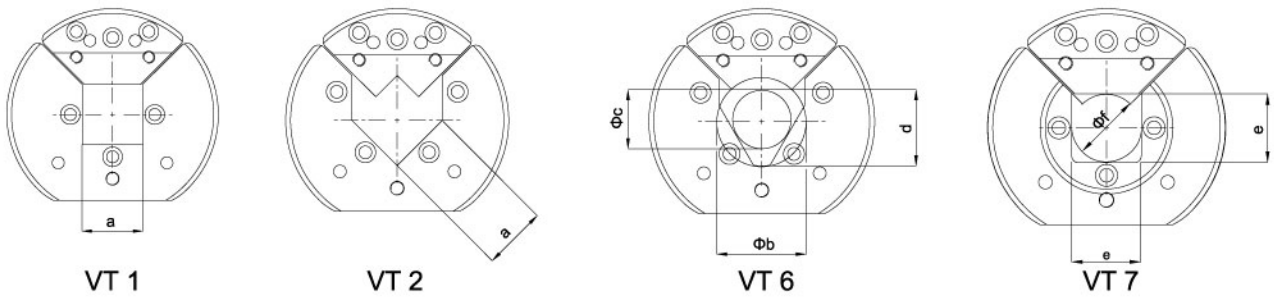

TYPE	VT1/VT2					VT6			VT7					
	a(mm)					Øb	Øc	Ød	e	Øf F7				
28	25	30				45	30	37.5	31	30				
35		30	32	35	40	55	36	45.5	41	40				
50					40	45	50	70	46	58	51	50		
75							50	60	80	105	67	86	51	50

VT2: 75 a = max. 63.5 注: 軸端尺寸在允許範圍內可依據需求定制 Other kit inserts are available at customer's request

卷軸兩側規格尺寸
Reel both-sides specification and size

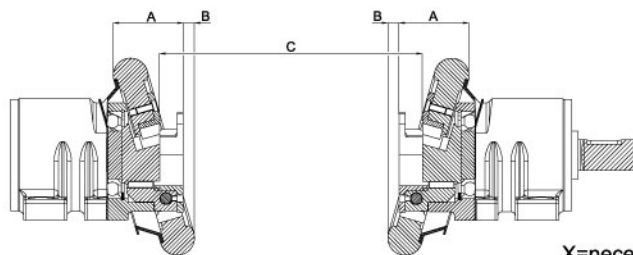
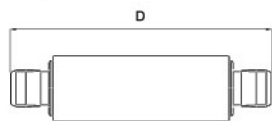

X=軸端間隙
X=necessary clearance

Size	A	B	x=(C-D)
28	61	8	0.5
35	73	13	0.5
50	81	13	0.5
75	106	16	0.5

卷軸兩端尺寸
Reel both-ends specification and size

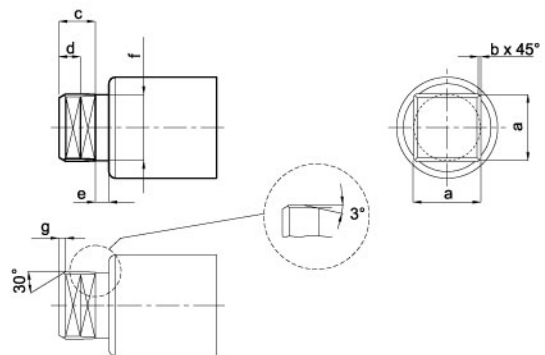
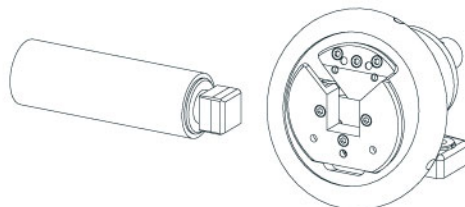

標準型 (Standard type)/VT1/VT2

Size	a f7	b	c	d	e	Ø f	g
28	22-30	1	21.5 -0.2	11	8	a-1 -0.1/-0.2	4
35	30-40	1.5	24 -0.2	12.5	10	a-1 -0.1/-0.2	5
50	40-50	2	26 -0.2	13.5	10	a-1 -0.1/-0.2	5
75	50-80	3	34 -0.3	17.5	17	a-1 -0.1/-0.3	6

卷軸兩端尺寸 Reel both-ends size

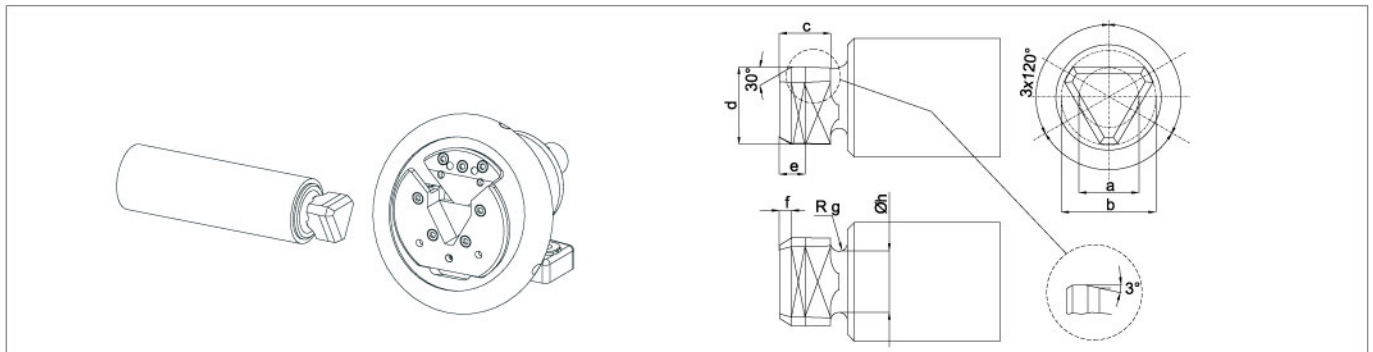

VT6

Size	a f7	b f7	c	d f7	e	f x 30°	g	h
28	30	44	21.5 -0.2	37	14	5	4	30 -0.1/-0.2
35	36	54	24 -0.2	45	15	7	5	36 -0.1/-0.2
50	46	69	26 -0.2	57.5	16	7	5	46 -0.1/-0.2
75	67	104	34 -0.3	85.5	20	7	8.5	67 -0.1/-0.4

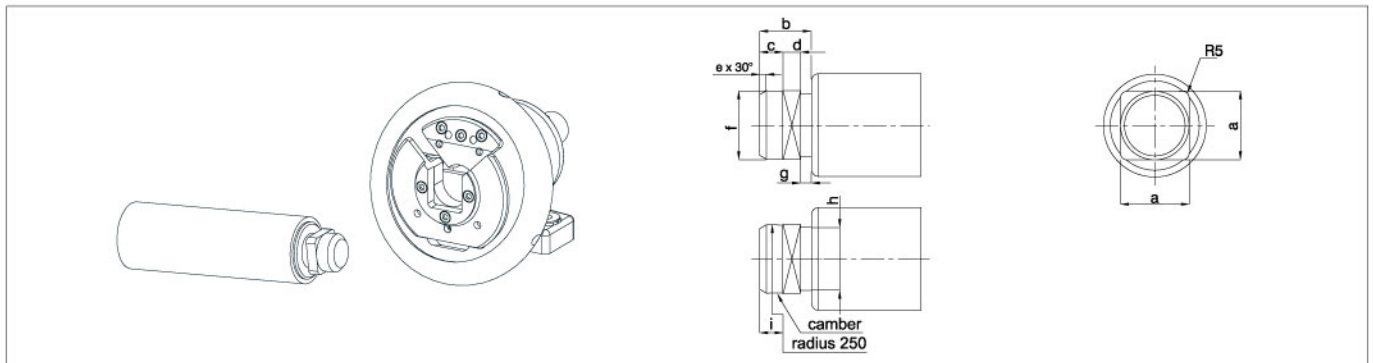

VT7

Size	a	b	c	d	e x 30°	Ø f h7	g	Ø h -0.2	i
28	30 +0.1/+0.3	32,5	14 +0.2/+0.3	10.5 -0.1	4	30	8 +0.1	26 -0.2	6
35	40 +0.1/+0.3	37	18 +0.2/+0.3	11 -0.1	5	40	8 +0.1	36 -0.2	6
50	50 +0.1/+0.3	38	17 +0.2/+0.3	13 -0.1	5	50	8 +0.1	46 -0.5	6
75	50 +0.2/-0.2	55	23 +0.2/+0.3	17 -0.1	6	50	15 +0.1	45 -0.2	9

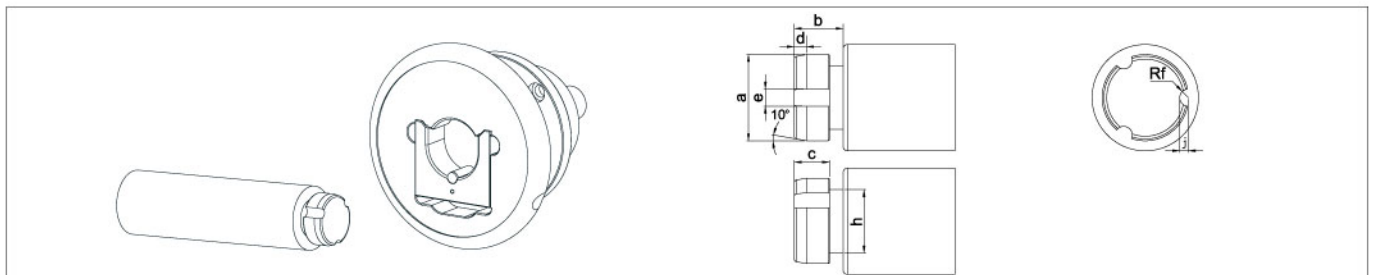

RD

Size	a f7	b	c	d	e	f F8	j F8	Øh
28	50	29.5	21.5 -0.2	7	10	5	5	39
35	60	34	24 -0.2	8.5	12	6	6	46
50	70	36	26 -0.2	9.5	14	7	7	53
75	80	51	34 -0.3	12	16	8	8	60

注：軸端尺寸在允許範圍內可依需求定制

Other kit inserts are available at customer's request

安全夾頭安裝注意事項 Safety chuck installation precautions

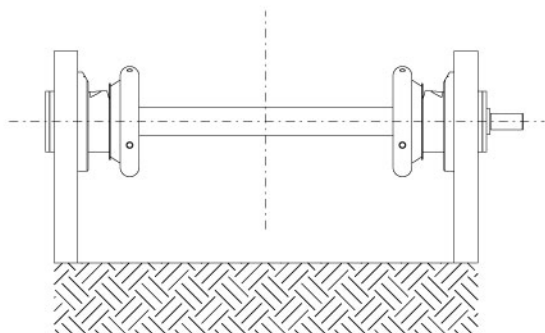
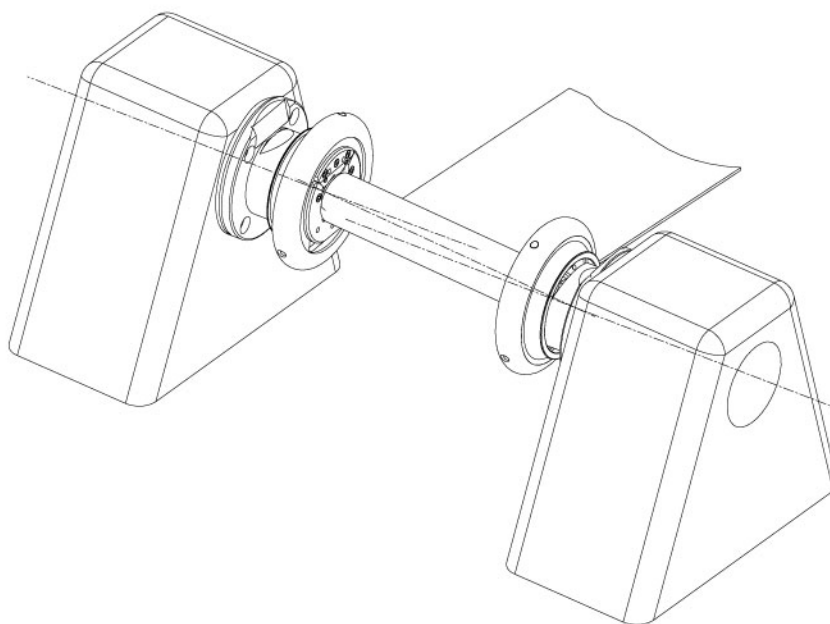

正確 CORRECT

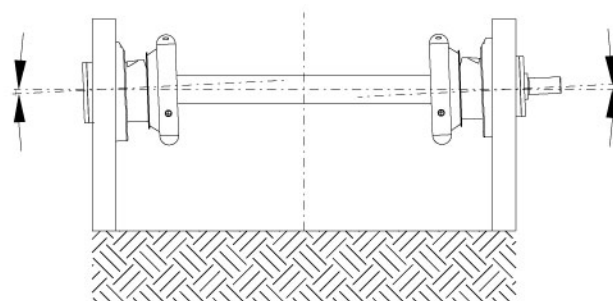

錯誤 WRONG

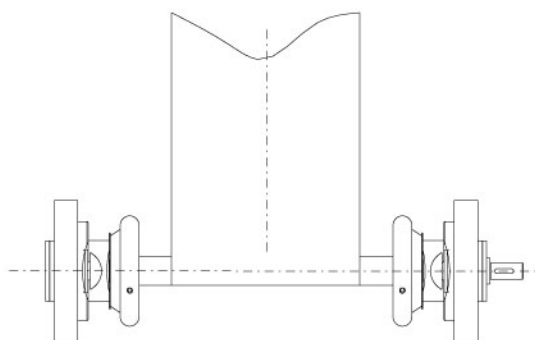

正確 CORRECT

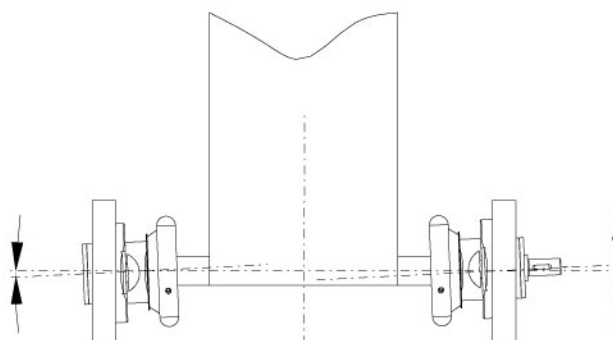

錯誤 WRONG

安全夾頭安裝注意事項 Safety chuck installation precautions

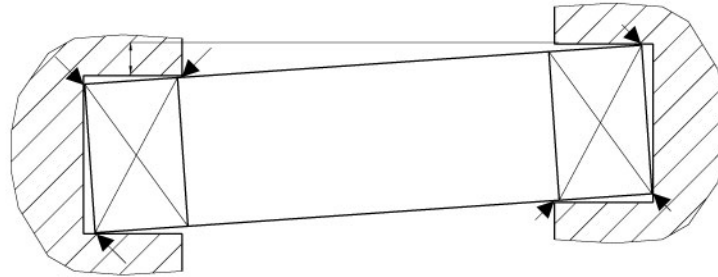

錯誤 WRONG

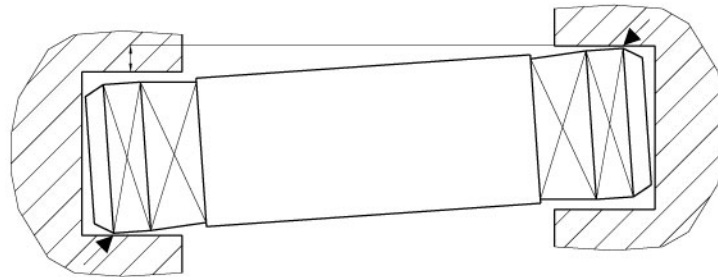

錯誤 WRONG

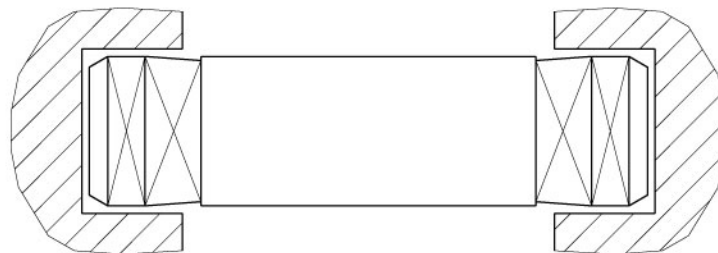

正確 CORRECT

STEKI的安全夾頭制造時已經保證了工藝精度在誤差允許範圍之內，但是在安裝上請注意安裝孔的定位，確實實施軸心綫同心度的校准。

卷軸安置后的不同心度勿超過 0.3° ，將有助于軸端與安全夾頭托口的快速安放與脫離，并保證卷軸與夾頭減少磨損延長壽命。如果誤差過大，并將引起料架和整機的振動，請特別關注。

STEKI safety chucks have guaranteed the art precision within allowable tolerance, however, you need pay attention to the positioning of mounting hole in installation to conduct alignment between reel and safety chuck.

The concentricity of reel after installation should not be more than 0.3° , which will make easier laying or releasing between reel and safety chuck and prolong the life time for reel due to fewer friction between them.

If beyond tolerance, it may vibrate the reel or the whole machine, so please pay special attention to it.

安全夾頭與手動制動器的配合 Coordination between safety chuck and manual brake

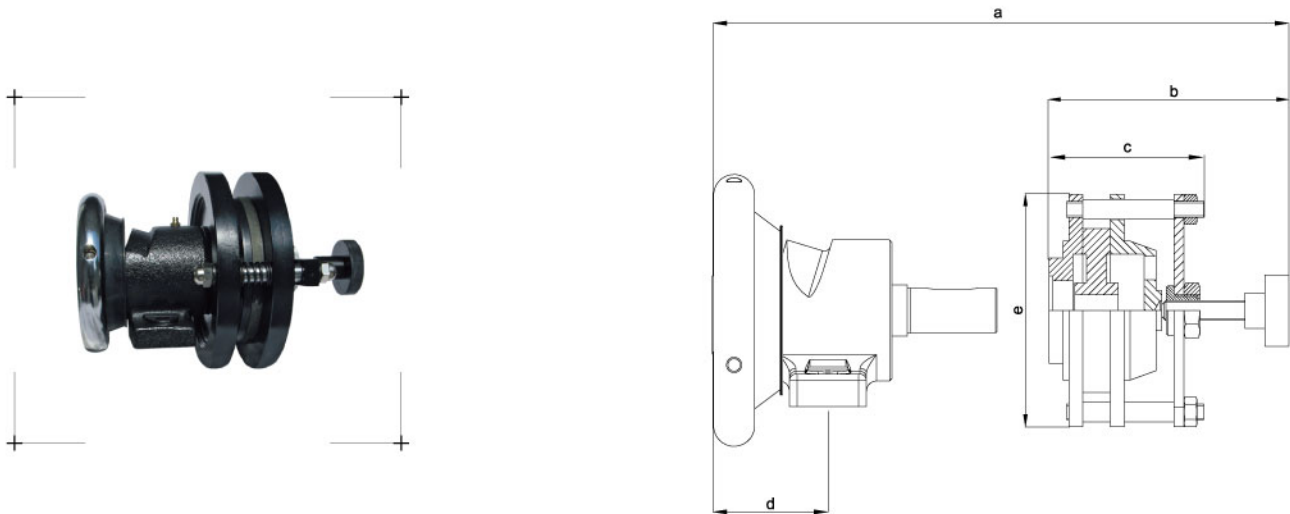

型號 Model	轉矩 Torque kg/m(N/m) [min-max]	a	b	c	e
TYPE 28 + ESB200	0.2(2)–4(40)	250	118	86	Ø200
TYPE 35 + ESB200	0.2(2)–4(40)	270	118	86	Ø200
TYPE 50 + ESB200	0.2(2)–4(40)	318	118	86	Ø200
TYPE 75 + ESB200	0.2(2)–4(40)	398	118	86	Ø200

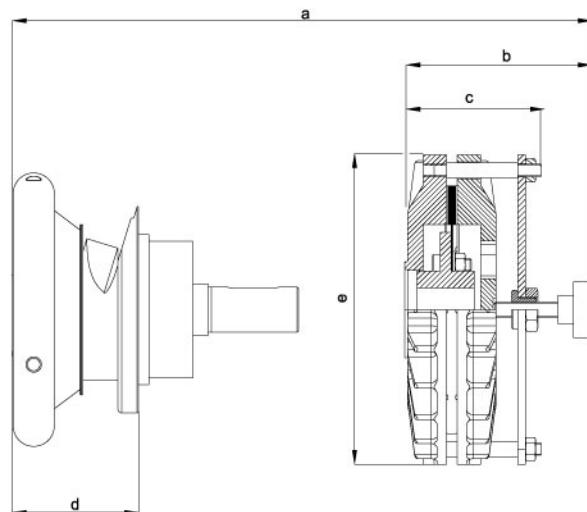

型號 Model	轉矩 Torque kg/m(N/m) [min-max]	a	b	c	e
TYPE 28 + ESB250	0.3(3)–5(50)	235	136.5	110	Ø250
TYPE 35 + ESB250	0.3(3)–5(50)	241	136.5	110	Ø250
TYPE 50 + ESB250	0.3(3)–5(50)	258	136.5	110	Ø250
TYPE 75 + ESB250	0.3(3)–5(50)	327	136.5	110	Ø250

特性 Features

滑動安全夾頭允許卷軸在機器運轉過程進行軸向調整。
 調整可以通過手輪或者自動機構進行。
 軸向定位裝置確保卷軸安全, 準確的傳遞轉矩。
 Slip safety chuck allows reel to have axial adjustment in the running of machine.
 You can adjust by manual or through automatic machine.
 Axial location device can assure security of reel, accuracy of torque transmitted.



法蘭型滑動安全夾頭 Flange type slip safety chuck

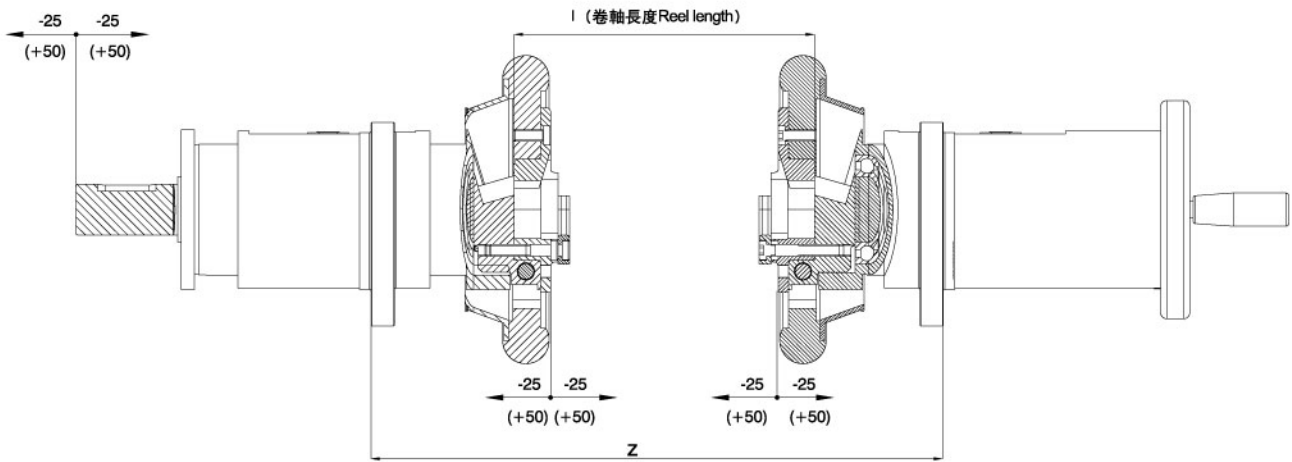

軸座型滑動安全夾頭 Pedestal type slip safety chuck

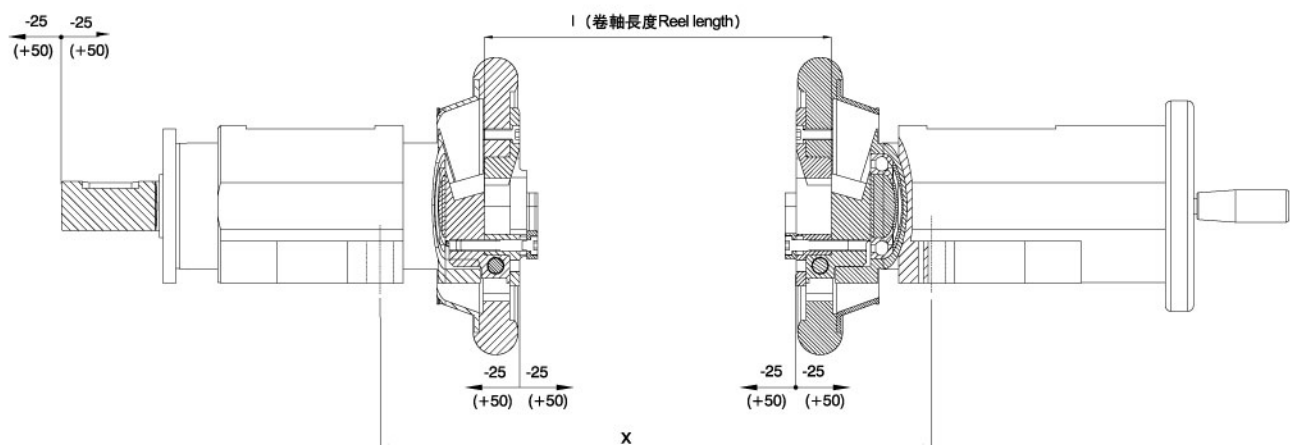

50 mm 滑動行程 (Slip stroke)

型號 Model	28	35	50
x	I+156	I+156	I+176
z	I+188	I+197	I+219

100 mm 滑動行程 (Slip stroke)

型號 Model	35	50
x	I+206	I+226
z	I+247	I+269

x = 固定間距 Fixed distance

SKW軸座型滑動安全夾頭 SKW pedestal type slip safety chuck

型號	Model	28	35	50
梁最大荷重量	Maximum load weight [kg]	700	1400	2800
承受最大轉矩	Withstand the maximum torque kg/m[N/m]	15(150)	30(300)	110(1100)
卷軸軸端允許尺寸	Reel end permissible size [mm]	22-30	30-40	40-50

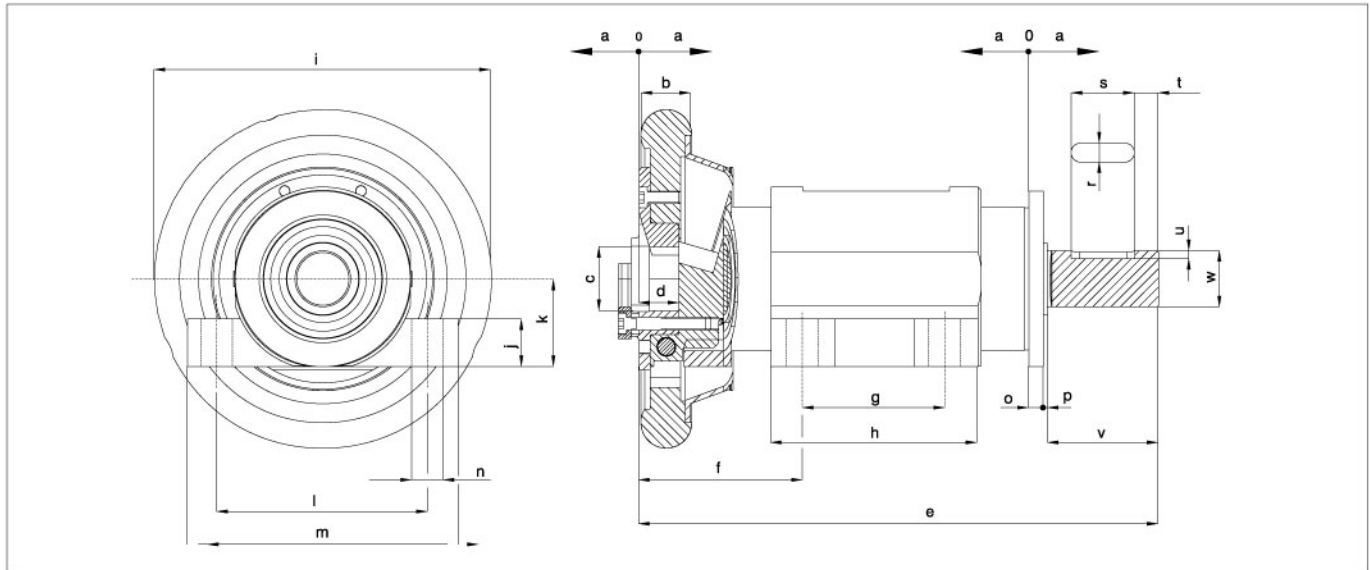

型號 Model	28	35	35	50	50
滑動行程 Slip stroke	50	50	100	50	100
a	25	25	50	25	50
b	25	32	32	40	40
c	28	35	35	50	50
d	22	25	25	27	27
e	322.5	338.5	438.5	372.5	472.5
f	100	103	128	115	140
g	90	90	90	80	80
h	130	130	130	130	130
Ø i	160	212	212	235	235
j	18	30	30	28	28
k	50	55	55	75	75
L	110	140	140	160	160
m	145	168	168	200	200
Ø n	13	14	14	14	14
o	12	12	12	12	12
p	1.5	2.5	2.5	2.5	2.5
r p9	8	12	12	14	14
s	40	70	70	90	90
t	15	6	6	10	10
u	4	5	5	5.5	5.5
v	70	82	82	110	110
Ø w k6	28	35	42	50	50

注：軸端尺寸在允許範圍內可依據需求定制 Other kit inserts are available at customer's request

SKO軸座型滑動安全夾頭 SKO pedestal type slip safety chuck

型號	Model	28	35	50
梁最大荷重量	Maximum load weight [kg]	700	1400	2800
承受最大轉矩	Withstand the maximum torque kg/m[N/m]	15(150)	30(300)	110(1100)
卷軸軸端允許尺寸	Reel end permissible size [mm]	22-30	30-40	40-50

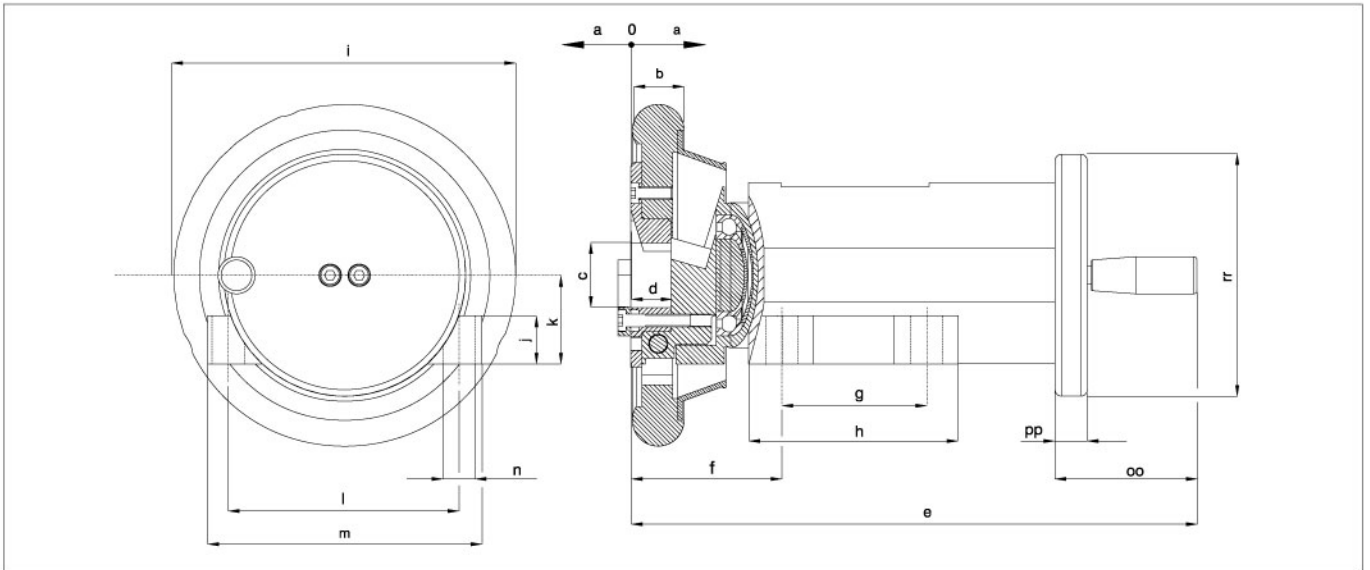

型號 Model	28	35	35	50	50
滑動行程 Slip stroke	50	50	100	50	100
a	25	25	50	25	50
b	25	32	32	40	40
c	28	35	35	50	50
d	22	25	25	27	27
e	357.5	360.5	435.5	381.5	456.5
f	100	103	128	115	140
g	90	90	90	80	80
h	130	130	130	130	130
Ø i	160	212	212	235	235
j	18	30	30	28	28
k	50	55	55	75	75
L	110	140	140	160	160
m	145	168	168	200	200
Ø n	13	14	14	14	14
oo	83.5	87.5	87.5	102.5	102.5
pp	16	20	20	20	20
Ø rr	128	150	150	168	168

注：軸端尺寸在允許範圍內可依需求定制 Other kit inserts are available at customer's request

SKWF法蘭型滑動安全夾頭 SKWF flange type slip safety chuck

型號	Model	28	35	50
梁最大荷重量	Maximum load weight [kg]	700	1400	2800
承受最大轉矩	Withstand the maximum torque kg/m[N/m]	15(150)	30(300)	110(1100)
卷軸軸端允許尺寸	Reel end permissible size [mm]	22-30	30-40	40-50

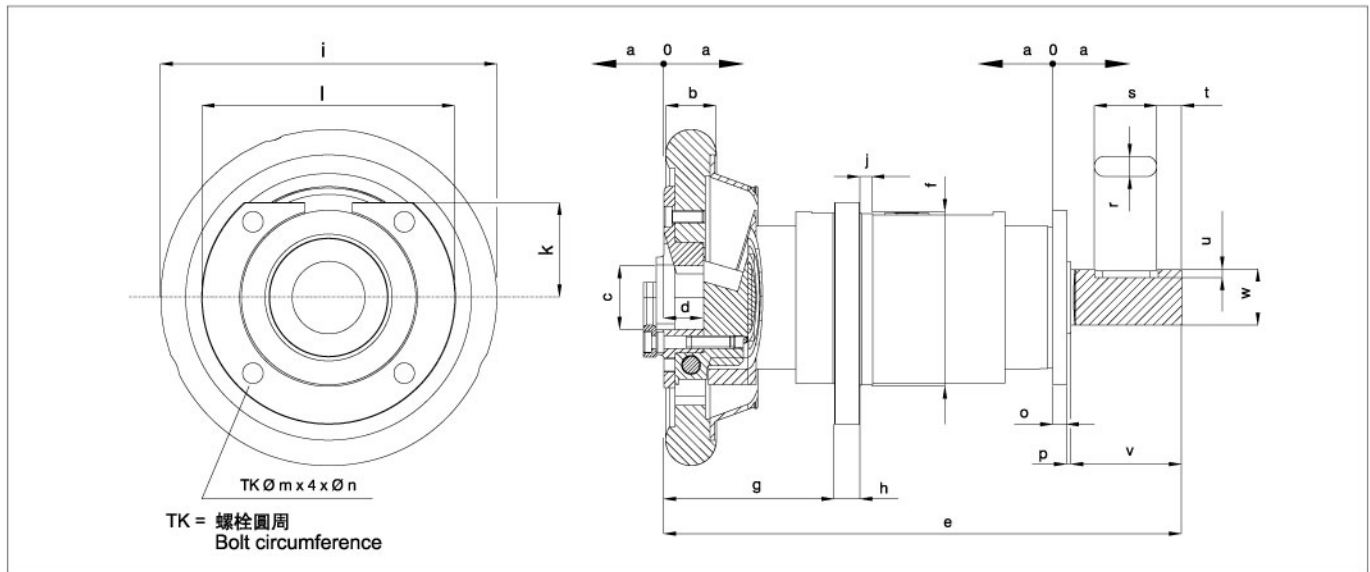

型號 Model	28	35	35	50	50
滑動行程 Slip stroke	50	50	100	50	100
a	25	25	50	25	50
b	25	32	32	40	40
c	28	35	35	50	50
d	22	25	25	27	27
e	322.5	338.5	438.5	372.5	472.5
$\varnothing f f7$	100	110	110	140	140
g	100	107.5	132.5	114.5	139.5
h	16	16	16	22	22
$\varnothing i$	160	212	212	235	235
j	4	8	8	8	8
k	55	60	60	77	77
$\varnothing L$	145	160	160	210	210
$\varnothing m$	120	135	135	170	170
$\varnothing n$	11	13	13	18	18
o	12	12	12	12	12
p	1.5	2.5	2.5	2.5	2.5
r p9	8	12	12	14	14
s	40	70	70	90	90
t	15	6	6	10	10
u	4	5	5	5.5	5.5
v	70	82	82	110	110
$\varnothing w k6$	28	42	42	50	50

注：軸端尺寸在允許範圍內可依據需求定制 Other kit inserts are available at customer's request

SKOF法蘭型滑動安全夾頭 SKOF flange type slip safety chuck

型號	Model	28	35	50
梁最大荷重量	Maximum load weight [kg]	700	1400	2800
承受最大轉矩	Withstand the maximum torque kg/m[N/m]	15(150)	30(300)	110(1100)
卷軸軸端允許尺寸	Reel end permissible size [mm]	22-30	30-40	40-50

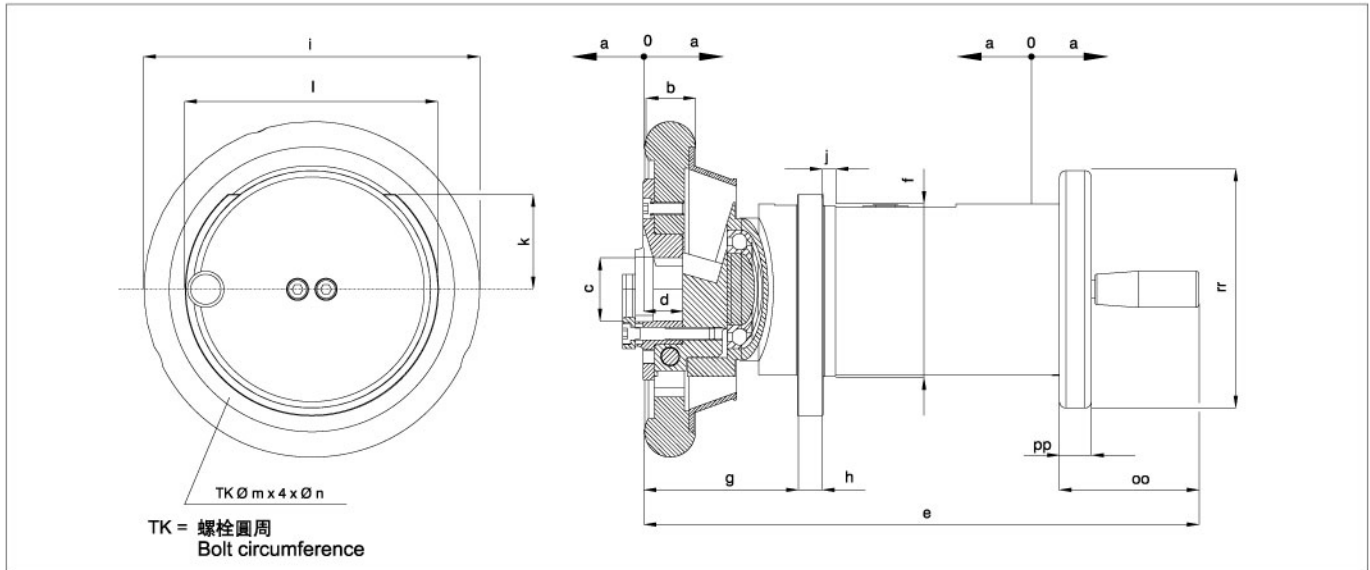

型號 Model	28	35	35	50	50
滑動行程 Slip stroke	50	50	100	50	100
a	25	25	50	25	50
b	25	32	32	40	40
c	28	35	35	50	50
d	22	25	25	27	27
e	357.5	360.5	435.5	381.5	456.5
Ø f f7	100	110	110	140	140
g	100	107.5	132.5	114.5	139.5
h	16	16	16	22	22
Ø i	160	212	212	235	235
j	4	8	8	8	8
k	55	60	60	77	77
L	145	160	160	210	210
m	120	135	135	170	170
Ø n	11	13	13	18	18
oo	83.5	87.5	87.5	102.5	102.5
pp	16	20	20	20	20
Ø rr	128	150	150	168	168

注：軸端尺寸在允許範圍內可依據需求定制 Other kit inserts are available at customer's request

傳動裝置法蘭固定型滑動安全夾頭 Wheelwork flange fixation type slip safety chuck

型號	Model	28	35	50
梁最大荷重量	Maximum load weight [kg]	700	1400	2800
承受最大轉矩	Withstand the maximum torque kg/m[N/m]	15(150)	30(300)	110(1100)
卷軸軸端允許尺寸	Reel end permissible size [mm]	22-30	30-40	40-50

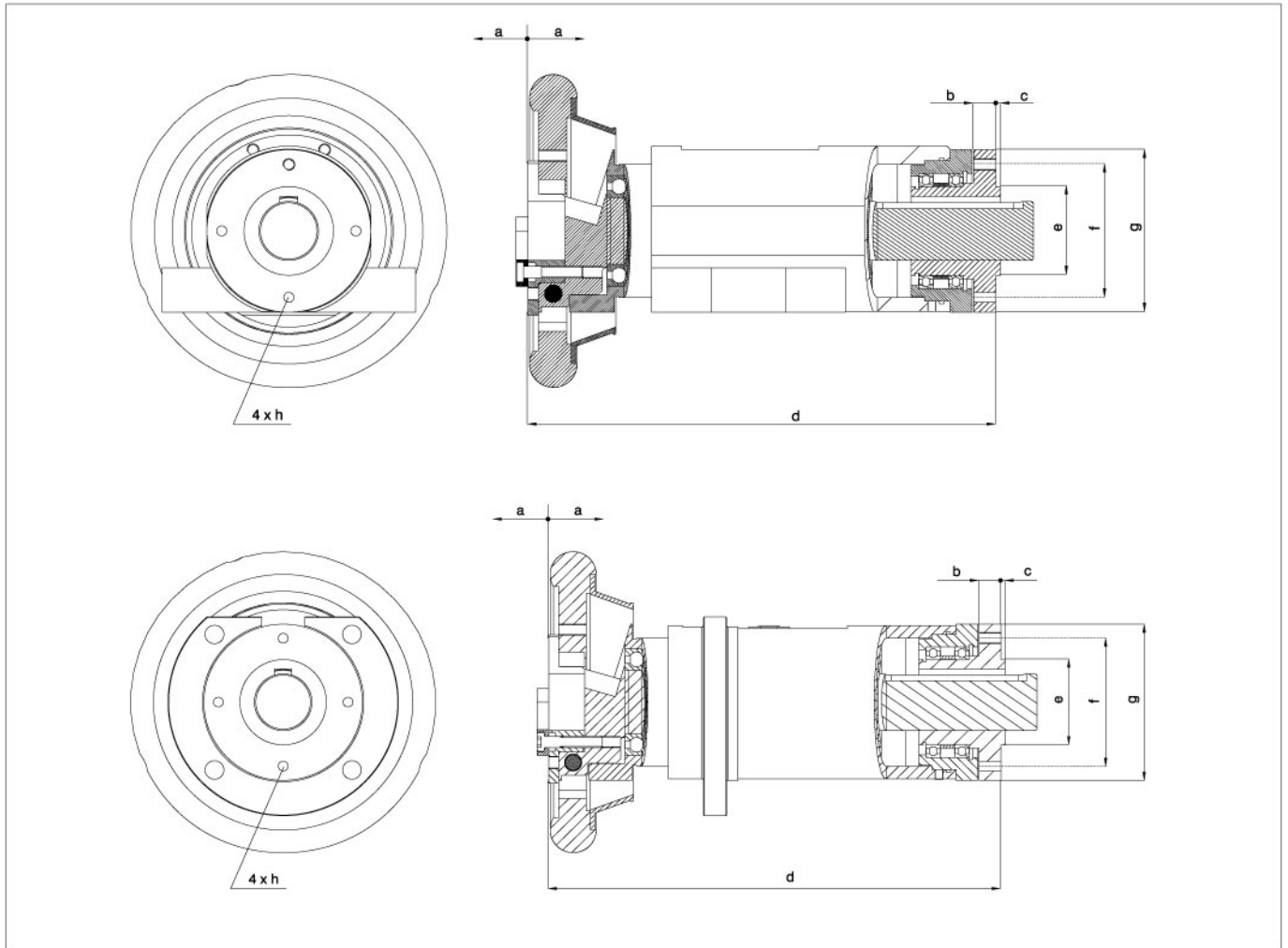

型號 Model	28	35	35	50	50
滑動行程 Slip stroke	50	50	100	50	100
a	25	25	50	25	50
b	12	15	15	15	15
c	3	3	3	3	3
d	308	314	389	329.5	404.5
Ø e	50	60	60	76	76
Ø f	75	90	90	110	110
Ø g	98	110	110	138	138
h	M8	M8	M8	M10	M10

注：軸端尺寸在允許範圍內可依據需求定制 Other kit inserts are available at customer's request

軸向定位尺寸 Axial location size

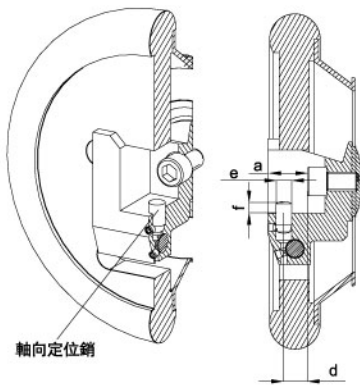

軸向定位銷

軸向定位銷 (標準型 VT1型可選)
Axial location pin(Standard VT1 type optional)

型號 Model	28	35	50
a	22	25	27
d	12	25	14
Ø e m6	8	10	12
f	6	6	6

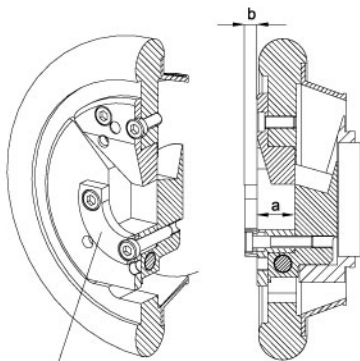

軸向定位環

軸向定位環 (標準型 VT1-VT6型可選)
Axial location ring (Standard VT6 type optional)

型號 Model	28	35	50
a	22	25	27
b	7	8	8

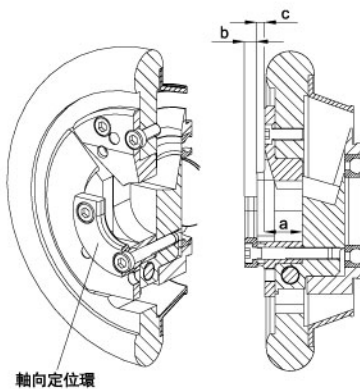

軸向定位環

軸向定位環 VT7型 Axial location ring VT7 type

型號 Model	28	35	50
a	22	25	27
b	7	8	8
c	3	5	4

注意：提升卷軸時請注意水平保持，過大的角度提升有可能產生較大的剪切力，使定位銷遭到損壞。
Note: Please keep balance if rise up the reel, overlarge angle rising may produce greater shear force and then damage the location pin.

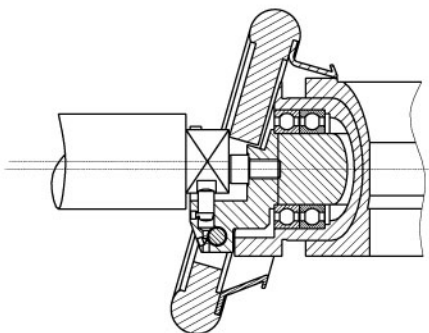

正確 Correct

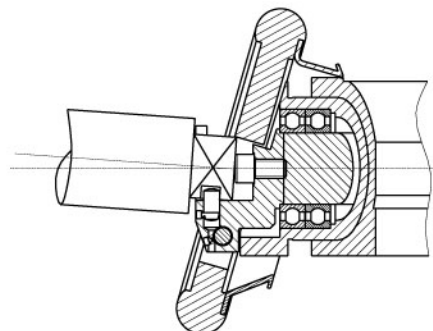

請選擇軸向定位環 Please choose axial location ring

軸向定位環尺寸 Axial location ring size

VT1

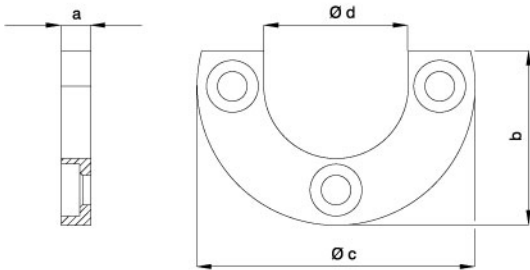

型號 Model	28	35	50
a	7	8	8
b	38	47	55
Ø c	60	75	90
Ø d	d=卷軸軸端尺寸 (Reel end size) -1+0.1		

VT2

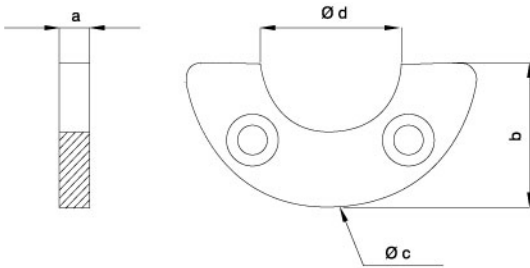

型號 Model	28	35	50
a	7	8	8
b	29	37	44
Ø c	60	75	90
Ø d	d=卷軸軸端尺寸 (Reel end size) -1+0.1		

VT6

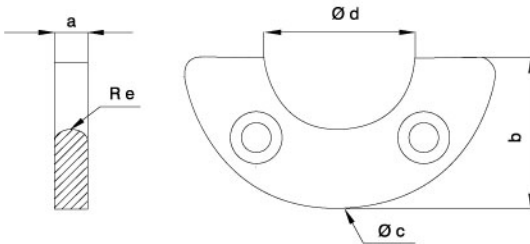

型號 Model	28	35	50
a	7	8	8
b	29	37	44
Ø c	60	75	90
Ø d	30 +0.1	36 +0.1	46 +0.1
Re	3.5	4	4

VT7

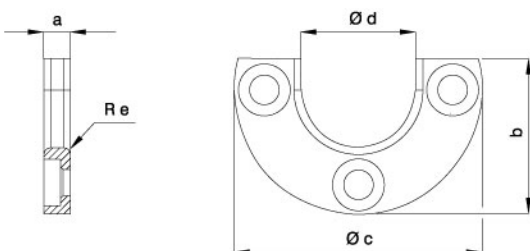

型號 Model	28	35	50
a	7.5	7.5	7.5
b	38	47	55
Ø c	60	75	90
Ø d	29	39	49
Re	2	2	2

型號	Model	FAO/FAW 28-	SAO/SAW 28-
梁最大荷重量	Maximum load weight [kg]	800	800
承受最大轉矩	Withstand the maximum torque kg/m[N/m]	23.5(235)	23.5(235)
最大工作速度	Maximum operating speed [Rpm]	600	600
重量	Weight [kg]	10	10

FAO/FAW 28

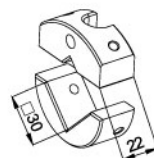
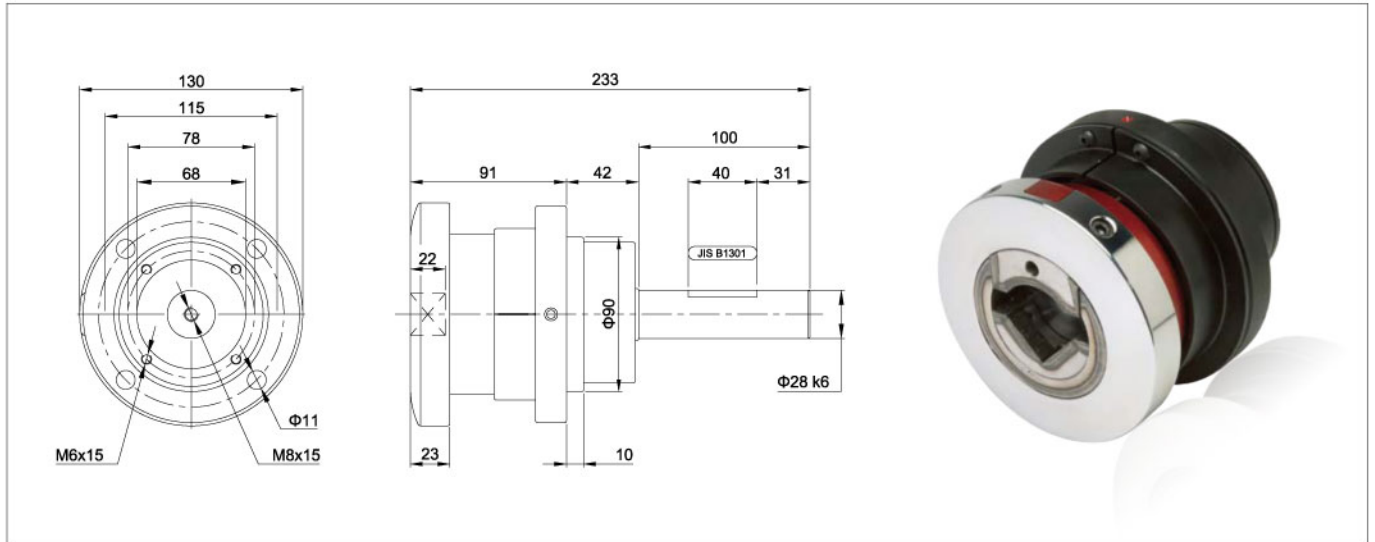

VT2

注：軸端尺寸在允許範圍內可依據需求定制

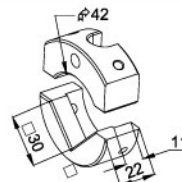

VT7

Other kit inserts are available at customer's request

SAO/SAW 28

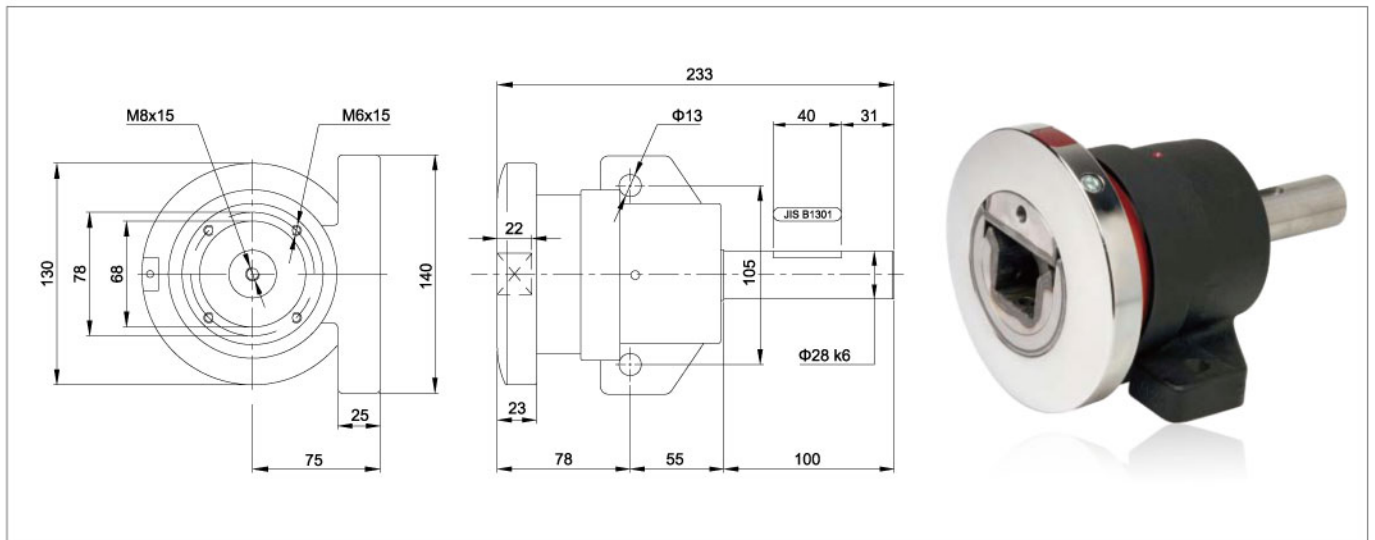

型號	Model	FAO/FAW 35-	SAO/SAW 35-
梁最大荷重量	Maximum load weight [kg]	1600	1600
承受最大轉矩	Withstand the maximum torque kg/m[N/m]	90(900)	90(900)
最大工作速度	Maximum operating speed [Rpm]	1100	1100
重量	Weight [kg]	13	13

FAO/FAW 35

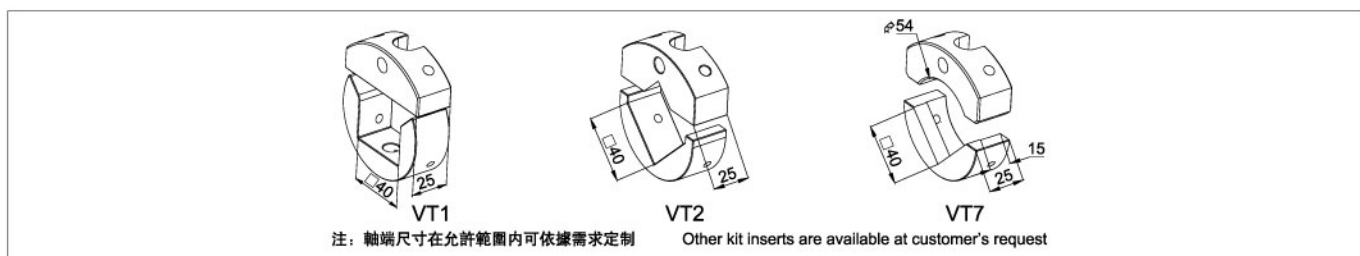
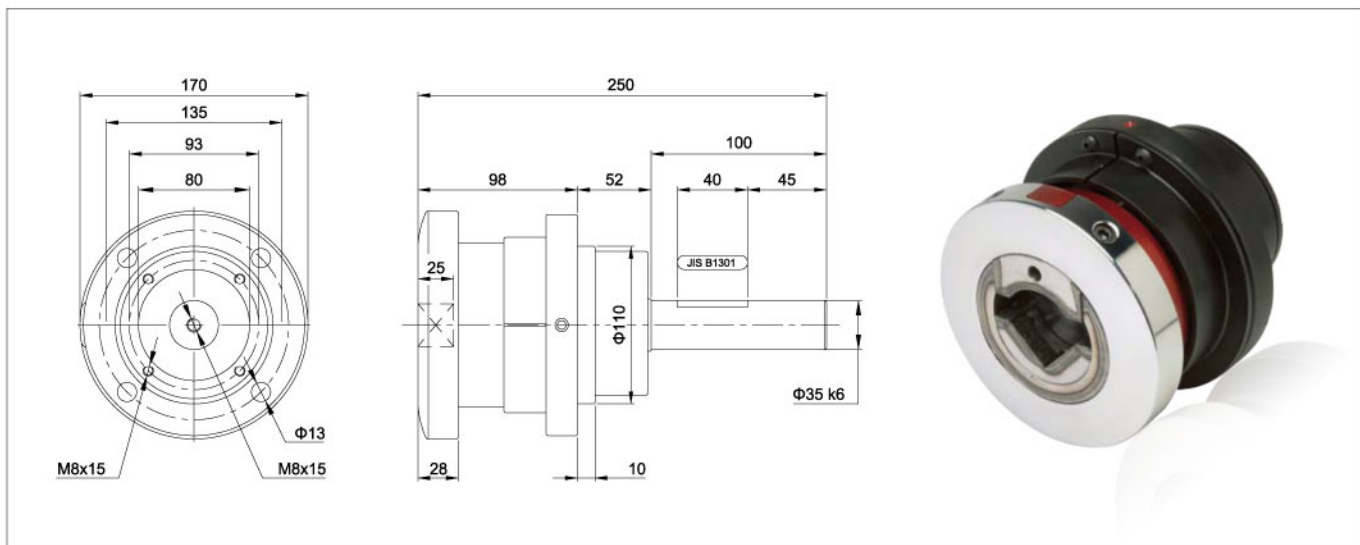

SAO/SAW 35

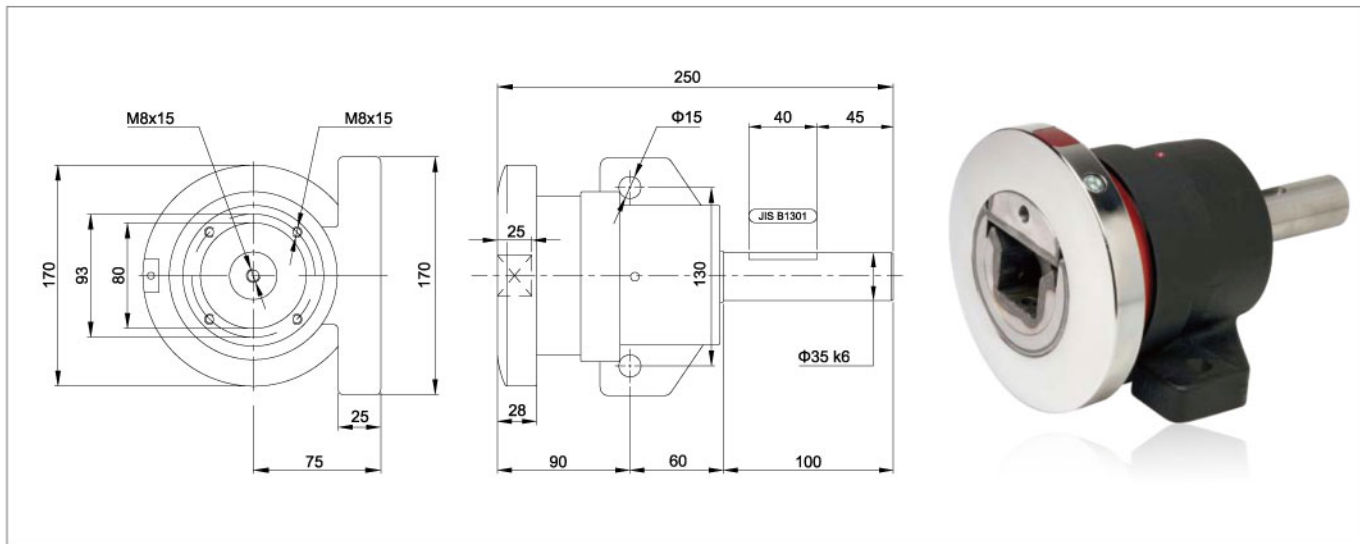

型號	Model	FEO/FEW 28-	SEO/SEW 28-
梁最大荷重量	Maximum load weight [kg]	350	350
承受最大轉矩	Withstand the maximum torque kg/m[N/m]	30(300)	30(300)
卷軸軸端允許尺寸	Reel end permissible size [mm]	25-30	25-30
重量 (約)	Weight [kg]	18	18

FEO/FEW 28

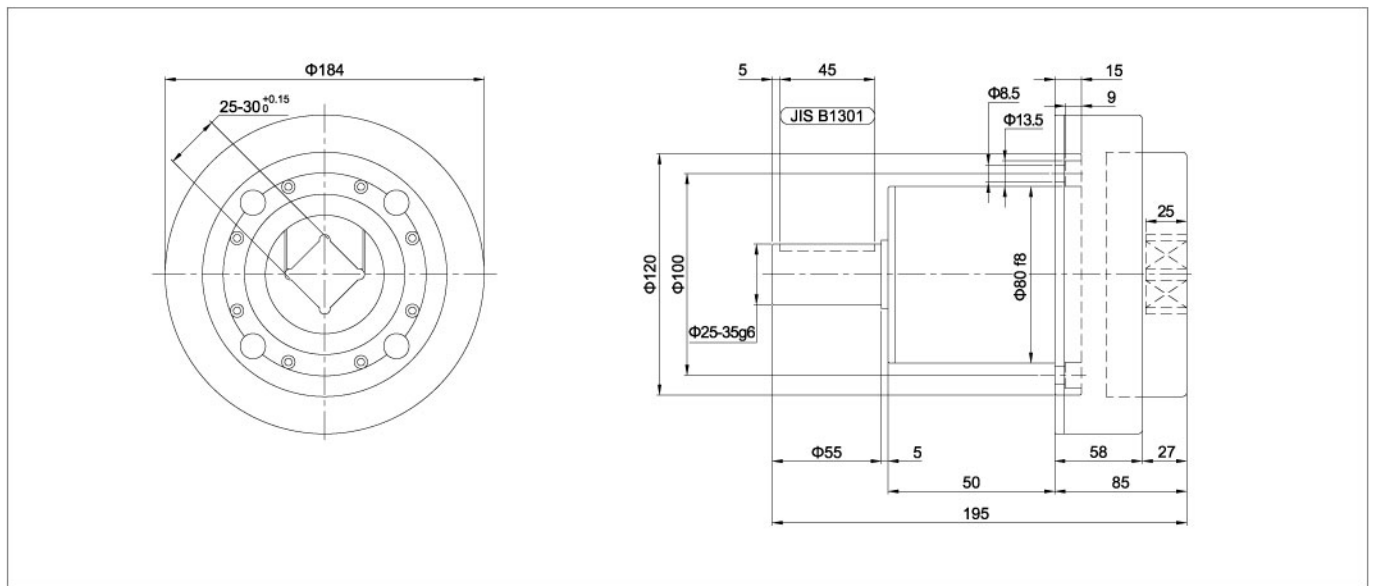

注：軸端尺寸在允許範圍內可依據需求定制 Other kit inserts are available at customer's request

SEO/SEW 28

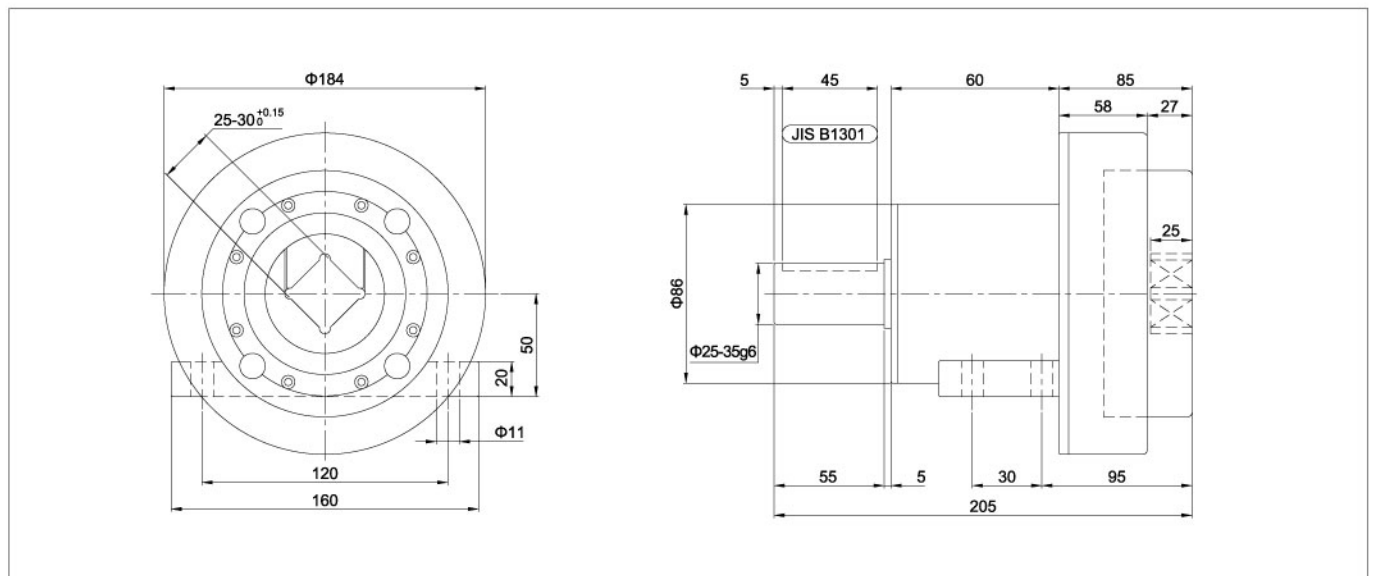

注：軸端尺寸在允許範圍內可依據需求定制 Other kit inserts are available at customer's request

型號	Model	FEO/FEW 35-	SEO/SEW 35-
梁最大荷重量	Maximum load weight [kg]	720	720
承受最大轉矩	Withstand the maximum torque kg/m[N/m]	90(900)	90(900)
卷軸軸端允許尺寸	Reel end permissible size [mm]	30-40	30-40
重量 (約)	Weight [kg]	25	25

FEO/FEW 35

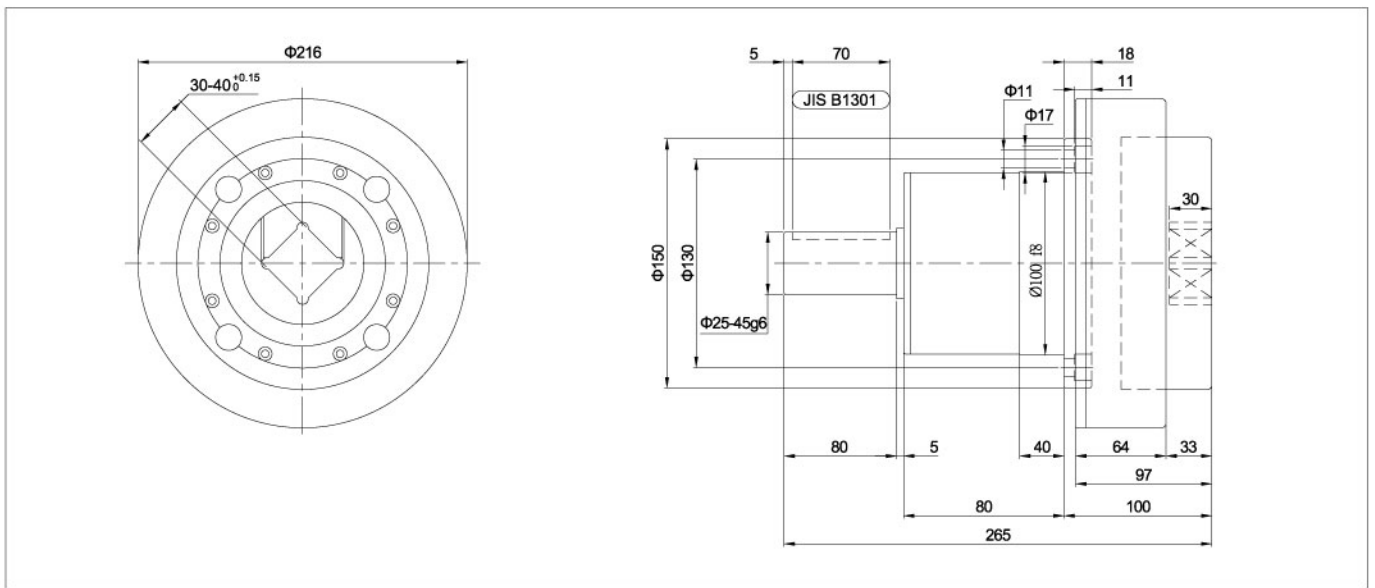

注：軸端尺寸在允許範圍內可依據需求定制 Other kit inserts are available at customer's request

SEO/SEW 35

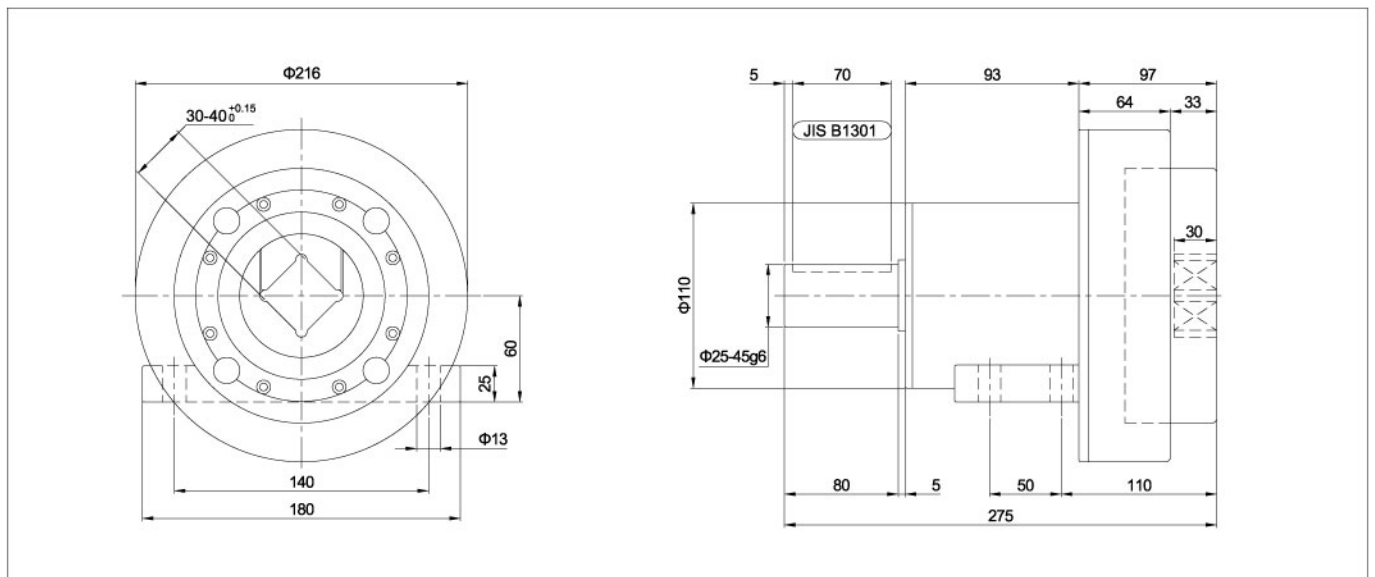

注：軸端尺寸在允許範圍內可依據需求定制 Other kit inserts are available at customer's request

型號	Model	FEO/FEW 50-	SEO/SEW 50-
梁最大荷重量	Maximum load weight [kg]	1400	1400
承受最大轉矩	Withstand the maximum torque kg/m[N/m]	130(1300)	130(1300)
卷軸軸端允許尺寸	Reel end permissible size [mm]	40-50	40-50
重量 (約)	Weight [kg]	50	50

FEO/FEW 50

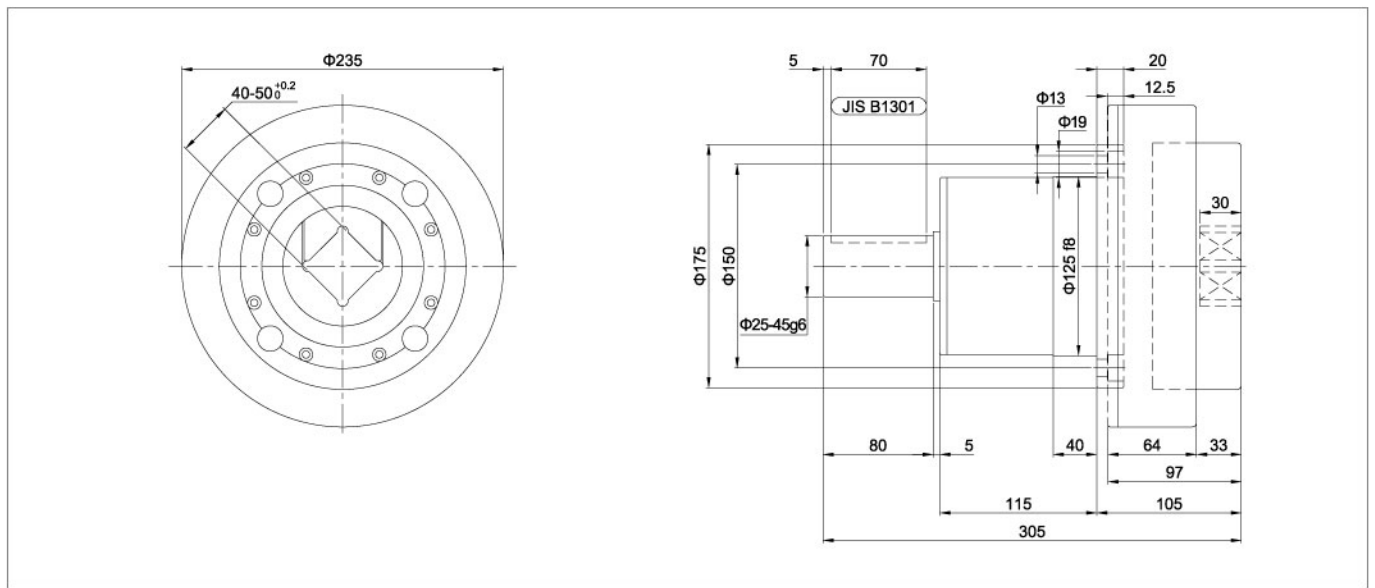

注：軸端尺寸在允許範圍內可依據需求定制 Other kit inserts are available at customer's request

SEO/SEW 50

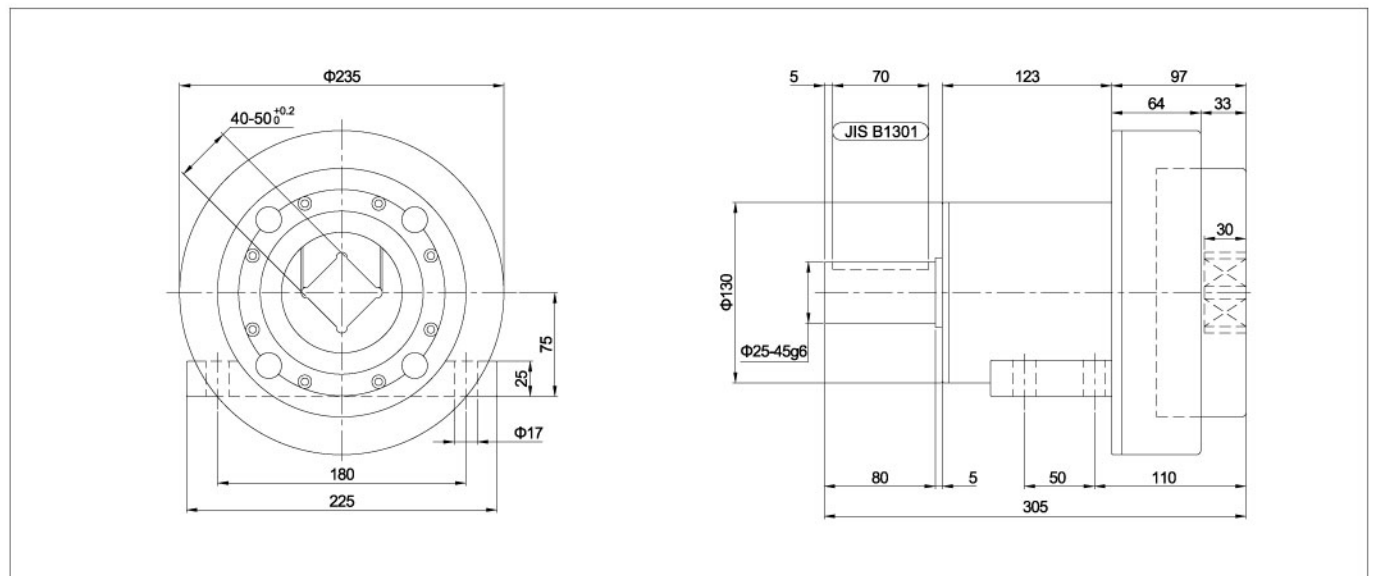

注：軸端尺寸在允許範圍內可依據需求定制 Other kit inserts are available at customer's request

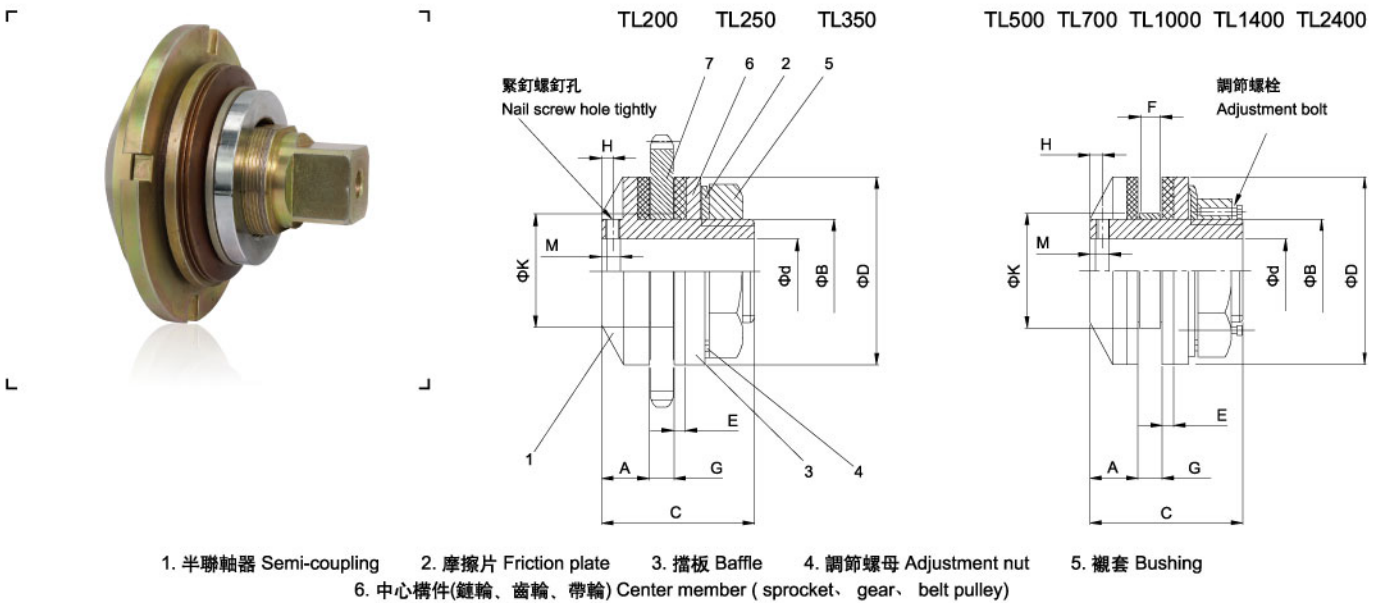

1. 半聯軸器 Semi-coupling 2. 摩擦片 Friction plate 3. 擋板 Baffle 4. 調節螺母 Adjustment nut 5. 襯套 Bushing
6. 中心構件(鏈輪、齒輪、帶輪) Center member (sprocket、 gear、 belt pulley)

標記示例 Tag example :TL500A 內孔 Bore :Φ35 標記為 Mark as :TL500A-35

型號 Model	扭矩範圍 Torque range N·m	許用轉速 Allowable running speed (rpm)	配套鏈輪節距及齒數(另計價) Mating sprocket pitch and teeth number (extra pricing)		ΦD	ΦB	ΦC	ΦA	ΦE	ΦF	ΦG	ΦH	ΦM	ΦK	Φd	重量 Weight
			節距 Sprocket pitch	齒數 Teeth number												
TL200-A	3-10	1800	12.7	16	50	24	29	6.5	2.5	3.8	7	-	-	30	6-14	0.2
TL200-B	6.3-20															
TL250-A	6.3-28	1800	12.7	22	65	35	48	16	3.2	4.5	9	4	5	41	8-22	0.55
TL250-B	14-56															
TL350-A	20-80	1800	15.875	24/26	89	42	62	19	3.2	6.5	16	6	6	49	10-25	1.25
TL350-B	40-140															
TL500-A	48-224	1800	19.05	28	127	65	76	22	3.2	6.5	16	7	8	74	12-42	3.2
TL500-B	90-400															
TL700-A	125-560	1800	25.4	28	178	95	98	24	3.2	9.5	29	8	10	105	15-64	6.8
TL700-B	224-1120															
TL1000-A	400-1300	1000	44.45	22	254	100	115	23	4.0	12.5	24	-	-	135	20-72	21
TL1000-B	600-1900															
TL1400-A	900-2720	500	50.8	26	356	145	150	31	4.0	15.5	29	-	-	183	30-100	52
TL1400-B	2000-4000									19.5						
TL2400-A	2500-5000	500	50.8	36	508	185	175	36	4.0	15.5	31	-	-	226	40-130	117
TL2400-B	4700-9500									19.5						

中心構件 Center member

中心構件的摩擦面加工時必須兩面平行，與內徑相垂直，不含任何灰塵，銹皮或油污，端面研磨為佳。如中心構件不符合本規範，則滑動扭矩不穩定，中心構件內徑的加工尺寸見上表ΦK值。

Please parallel the two friction facings in processing, make them vertical to the bore without any dust, rust, oil stain, but better with grinding end face. If center member don't fit this rule, sliding torque will be unstable. Please check the above ΦK value chart to see the finishing size of center member bore.

氣脹軸示意圖 GRAPHIC SCHEME FOR AIR SHAFT

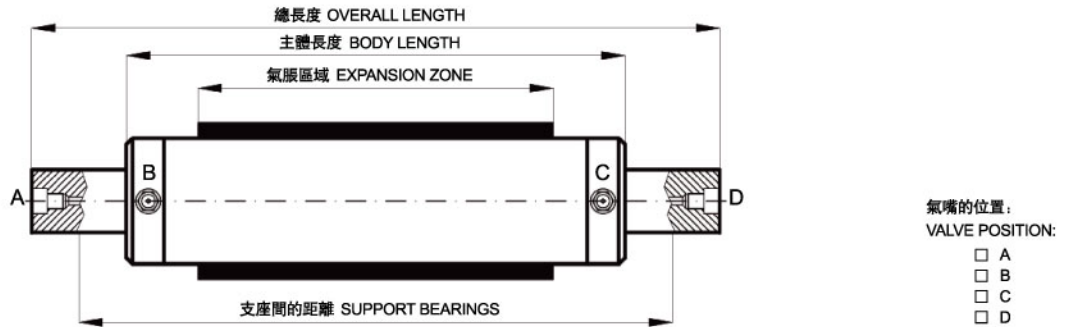

我們需要完整并解釋清晰的圖紙，請注明需要的淬硬區域。

WE ASK YOU TO SEND US A COMPLETE AND CONSTRUCTIVE DRAWING OF THE EXPANDING SHAFT, PLEASE MARK THE ZONE REQUESTS HARDEN.

基本參數 BISC INFORMATION

- 01. 機臺類型 MACHINE TYPE _____ 02. 機臺綫張力 MACHINE WIRE TENSION _____ 03. 機臺綫速度 MACHINE WIRE SPEED _____
- 04. 料卷材料 ROLL MATERIAL _____ 料卷最大外徑 ROLL MAX EXTERNAL DIAMETRE _____
料卷最小外徑 ROLL MIN EXTERNAL DAMETRE _____ 料卷幅寬 ROLL BREADTH _____
料卷最大重量 ROLL MAX WEIGHT _____
- 05. 料卷的數量 NUMBER OF ROLL _____ 06. 內芯直徑 INTERNAL CORE DIAMETRE _____
- 07. 內芯材料 CORE MATERIAL 紙板 CARDBOARD 塑料 PLASTIC 鋼 STEEL 其它 OTHER _____
- 08. 放卷 UNWINDING 收卷 WINDING

氣脹軸數據 AIR SHAFT DATA

- 01. 氣脹軸類型 AIR SHAFT TYPE 鍵條式 KEYS 板條式 LEAVES 通條式 STRIPS
 氣壓套夾 SLEEVE 滑差軸 DIFFERENTIAL 其它 OTHER _____
- 02. 氣脹軸主體材質 AIR SHAFT MATERIAL 鋼 STEEL 鋁 ALUMINIUM 碳纖維 CARBON FIBER
 其它 OTHER _____
- 03. 氣脹軸主體表面處理 AIR SHAFT BODY SURFACE TREATMENT 鋼 (電鍍類型) STEEL (ELECTRO PLATING TYPE) _____
鋁 (陽極處理) ALUMINIUM (ANODIZING) _____ 顏色 COLOR _____ 其它 OTHER _____
- 04. 氣脹軸直徑 AIR SHAFT DIAMETRE 75 148 其它 OTHER _____

注意事項 NOTE: _____

空壓制動器、空壓離合器、空油壓碟式制動器、氣動離合器制動器組、安全夾頭、機械夾頭、氣脹軸



DBK型空壓碟式制動器



NAB型空壓通軸式制動器



NAC型空壓通軸式離合器



DBK型空壓碟式制動器



DBG型空壓碟式制動器



DBH型空壓碟式制動器



DBN-F型安全碟式制動器



DBM型空油壓碟式制動器



BST型空油壓轉換器



氣脹軸



PCCU型氣動制動離合器組

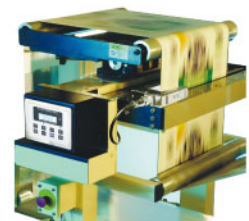

糾偏控制系統



機械夾頭



SKWSKO型滑動安全夾頭



FLWFO型安全夾頭